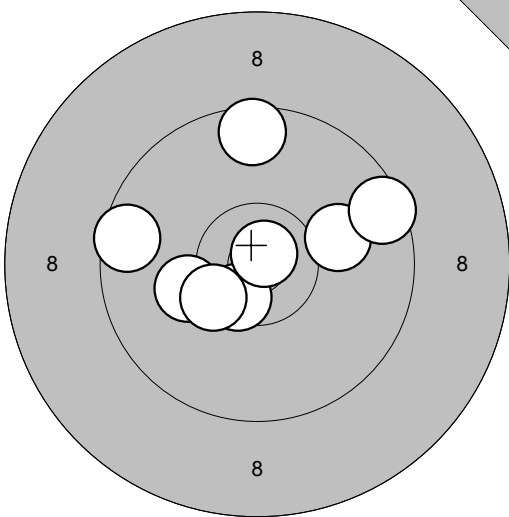
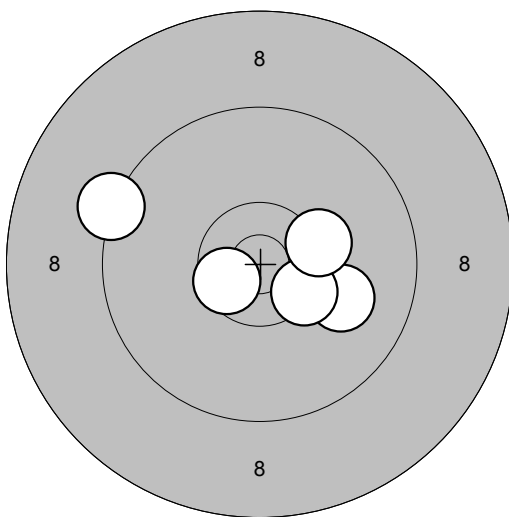
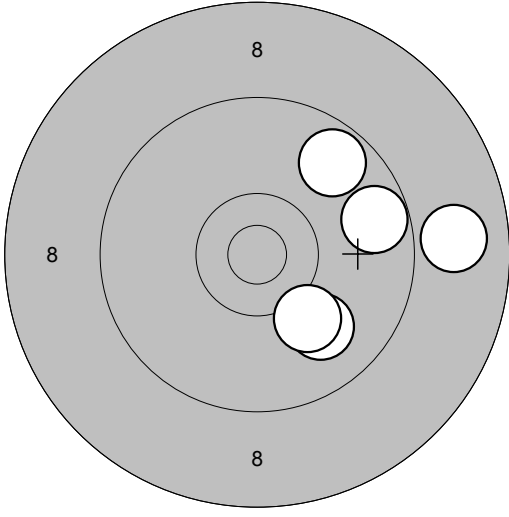
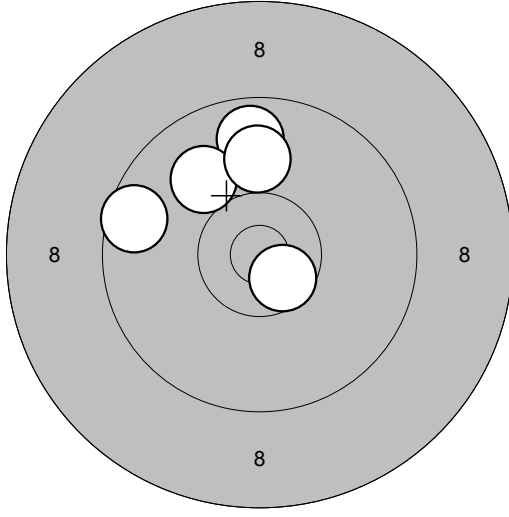
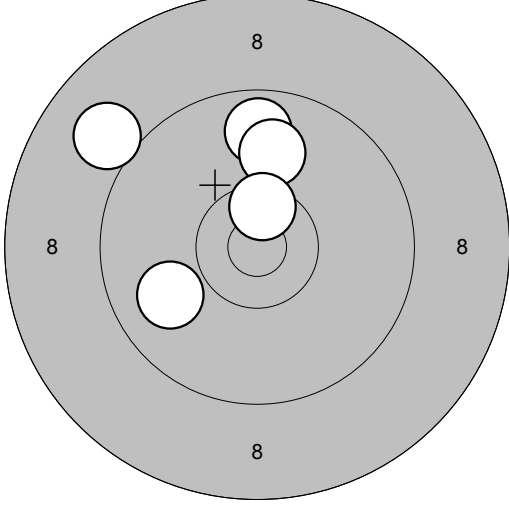
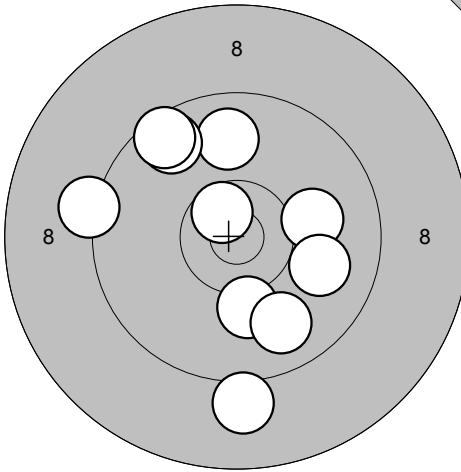
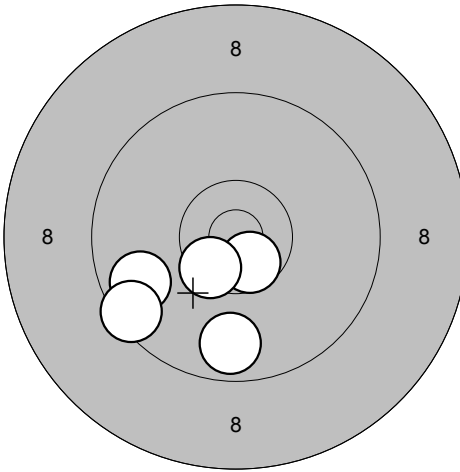
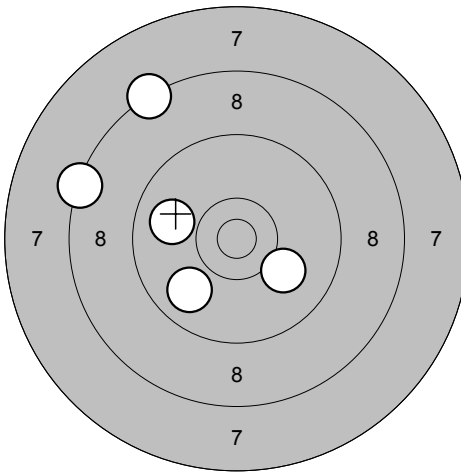
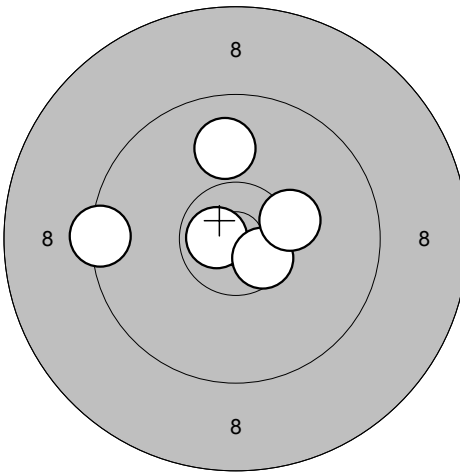

<p>Provsnitt</p> 	<p>1: 9,6 ←</p> <p>2: 10,6* ↘</p> <p>3: 10,8* ↗</p> <p>4: 10,2 ←</p> <p>5: 9,6 ↑</p> <p>6: 10,1 →</p> <p>7: 10,4* ←</p> <p>8: 9,5 →</p>	<p>20 Tävlingskott</p> 	<p>1: 10,6* ←</p> <p>2: 10,0 →</p> <p>3: 9,3 ←</p> <p>4: 10,4* ↘</p> <p>5: 10,3* →</p>
Serie	77,0	Serie	49,0
Totalt	0,0	Totalt	49,0

<p>20 Tävlingskott</p> 	<p>6: 8,9 →</p> <p>7: 9,9 ↘</p> <p>8: 10,1 ↘</p> <p>9: 9,7 →</p> <p>10: 9,7 ↗</p>	<p>20 Tävlingskott</p> 	<p>11: 9,7 ↑</p> <p>12: 10,0 ↗</p> <p>13: 9,6 ←</p> <p>14: 10,6* ↘</p> <p>15: 10,0 ↑</p>
Serie	45,0	Serie	48,0
Totalt	94,0	Totalt	142,0

<p>20 Tävlingskott</p> 	<p>16: 9,0 ↖</p> <p>17: 9,7 ↑</p> <p>18: 10,0 ↑</p> <p>19: 9,9 ←</p> <p>20: 10,5* ↑</p>		
Serie	47,0		
Totalt	189,0		

Provsnitt 	1: 10,1 → 2: 10,1 ↓ 3: 9,8 ↑ 4: 9,1 ↓ 5: 9,6 ↑ 6: 10,6* ↑ 7: 9,2 ← 8: 9,8 ↓ 9: 9,9 → 10: 9,6 ↑ Serie 93,0 Totalt 0,0	20 Tävlingskott 	1: 9,7 ↓ 2: 9,7 ← 3: 10,6* ↓ 4: 10,5* ↓ 5: 9,5 ← Serie 47,0 Totalt 47,0
---	---	---	---

20 Tävlingskott 	6: 9,9 ↓ 7: 10,1 ↓ 8: 8,3 ↑ 9: 9,9 ← 10: 8,3 ↑ Serie 44,0 Totalt 91,0	20 Tävlingskott 	11: 10,7* ← 12: 9,4 ← 13: 9,9 ↑ 14: 10,6* ↓ 15: 10,3* → Serie 48,0 Totalt 139,0
--	---	--	---

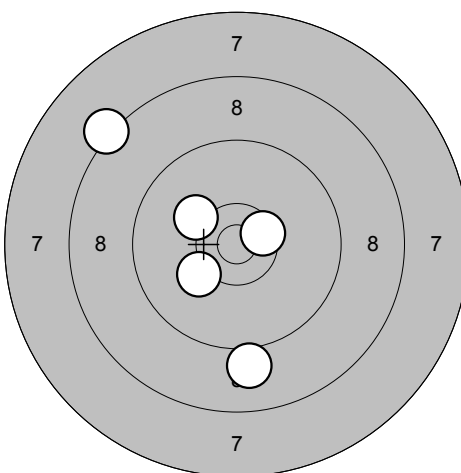
20 Tävlingskott 	16: 10,5* → 17: 8,2 ↑ 18: 10,2 ↓ 19: 9,0 ↓ 20: 10,2 ↑ Serie 47,0 Totalt 186,0		
---	---	--	--

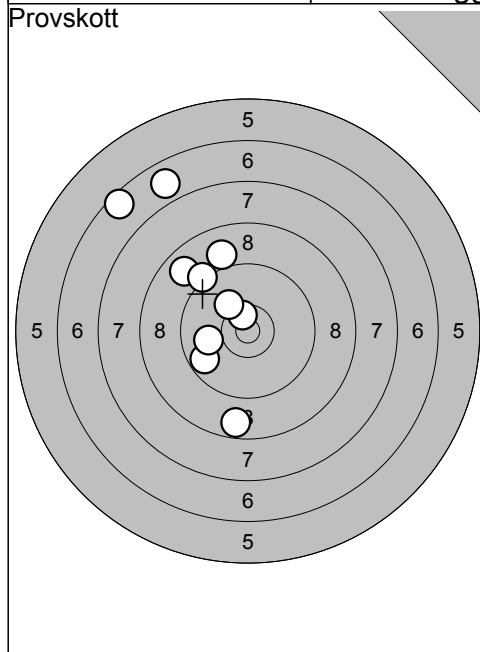

1: 6,8	↖
2: 9,7	↙
3: 10,0	←
4: 6,6	↗
5: 8,8	↗
6: 9,0	↗
7: 9,3	↗
8: 10,6*	↗
9: 10,2	↗
10: 8,7	↓
<hr/>	
Serie	85,0
Totalt	0,0

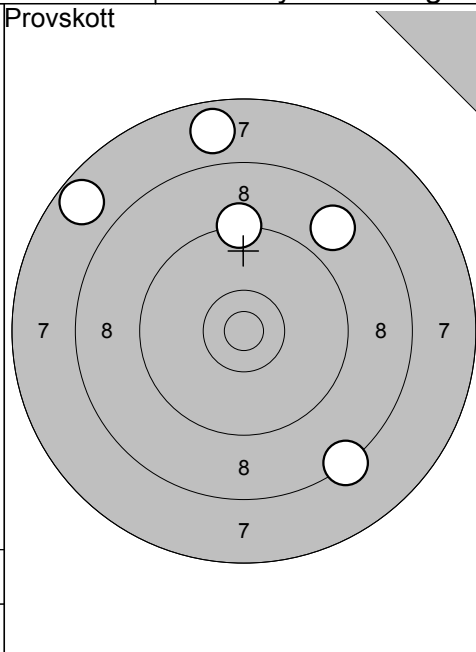

11: 7,7	↖
12: 9,3	↑
13: 8,3	↘
14: 8,8	↗
15: 7,8	↑
<hr/>	
Serie	39,0
Totalt	0,0

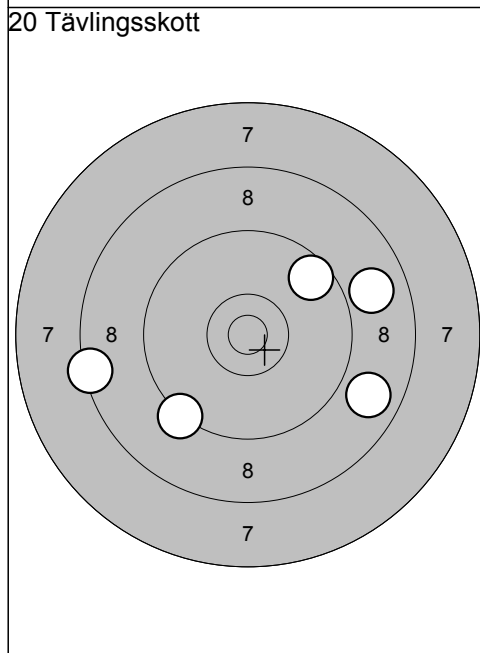

1: 8,4	←
2: 8,8	↘
3: 9,3	↙
4: 8,9	→
5: 9,6	↗
<hr/>	
Serie	42,0
Totalt	42,0

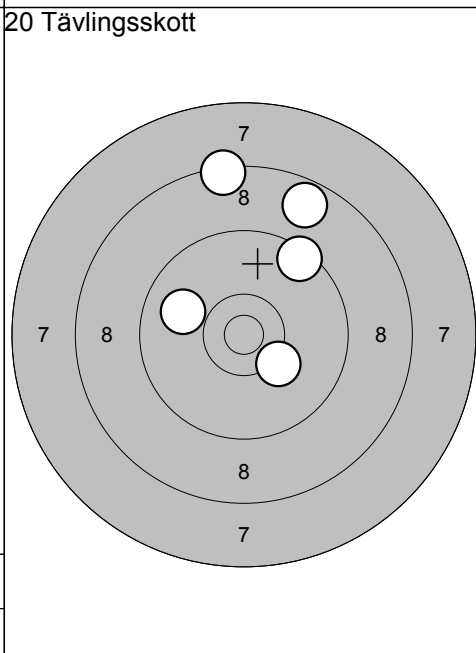

6: 9,5	↗
7: 8,4	↑
8: 8,7	↗
9: 9,9	←
10: 10,2	↘
<hr/>	
Serie	44,0
Totalt	86,0

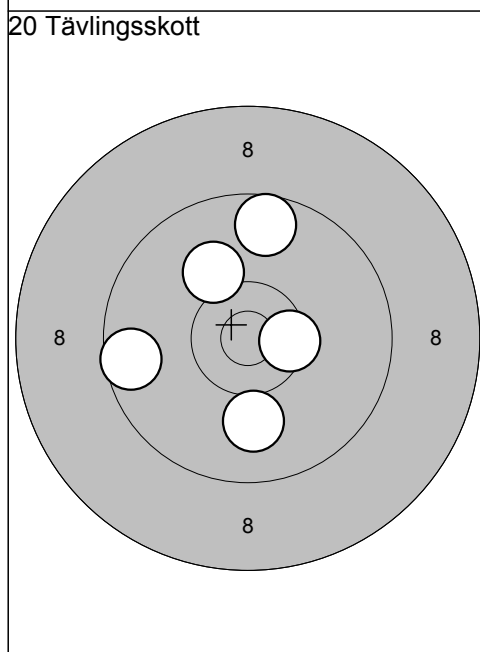

11: 9,6	↑
12: 10,5*	→
13: 9,6	←
14: 10,0	↓
15: 10,1	↗
<hr/>	
Serie	48,0
Totalt	134,0

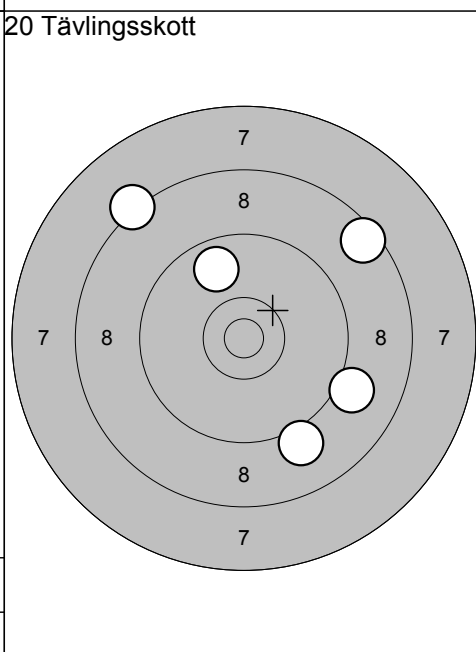

16: 9,8	↗
17: 9,1	↘
18: 8,2	↗
19: 9,1	↘
20: 8,5	↗
<hr/>	
Serie	43,0
Totalt	177,0

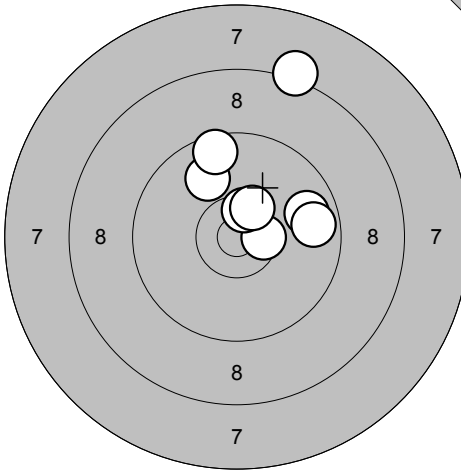
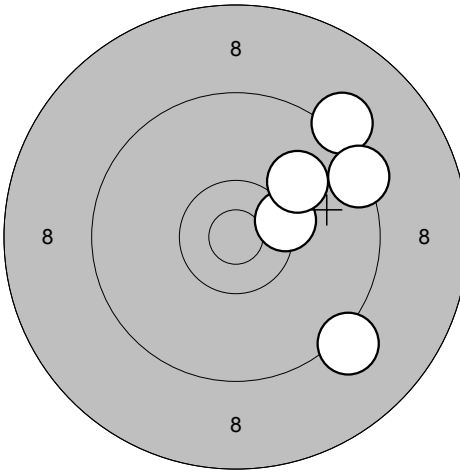
<b>Provsnitt</b> 	1: 8,2 ↗ 2: 10,5* → 3: 9,9 ↗ 4: 10,5* ↗ 5: 9,8 → 6: 9,6 ↗ 7: 9,7 → 8: 10,4* ↗	<b>20 Tävlingskott</b> 	1: 9,2 ↗ 2: 10,3* → 3: 9,2 ↘ 4: 10,0 ↗ 5: 9,4 ↗
Serie	74,0	Serie	47,0
Totalt	0,0	Totalt	47,0

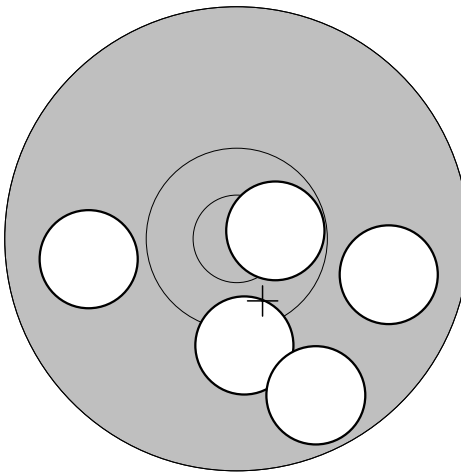
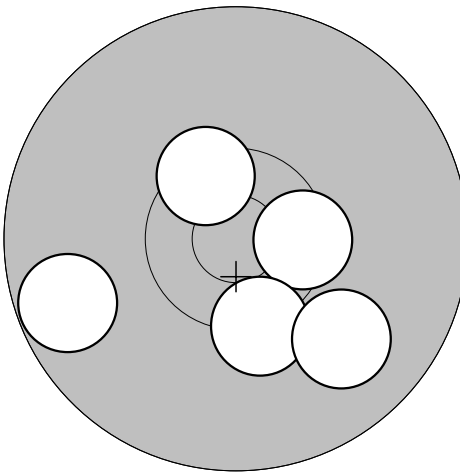
<b>20 Tävlingskott</b> 	6: 9,8 → 7: 9,9 ← 8: 10,7* → 9: 10,2 ↓ 10: 9,7 ↓	<b>20 Tävlingskott</b> 	11: 10,5* ↗ 12: 10,5* → 13: 10,3* ↓ 14: 9,7 ← 15: 9,9 ↘
Serie	47,0	Serie	48,0
Totalt	94,0	Totalt	142,0

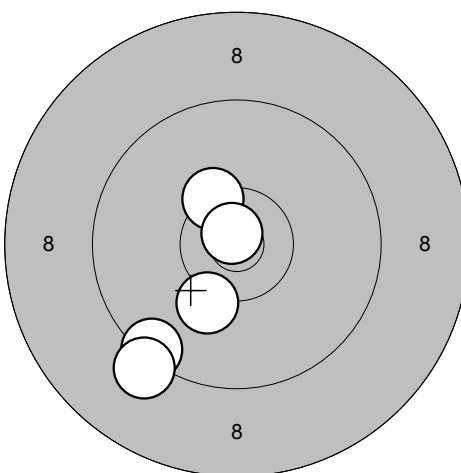
<b>20 Tävlingskott</b> 	16: 10,2 ↘ 17: 9,4 ↘ 18: 10,4* ↗ 19: 10,8* ↗ 20: 9,2 ↘		
Serie	48,0		
Totalt	190,0		

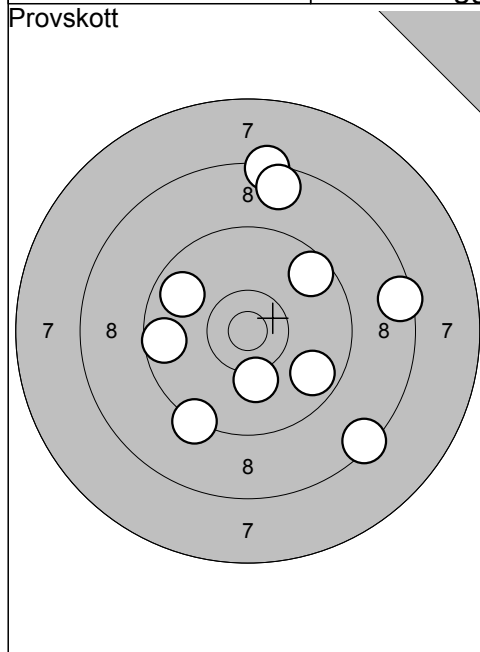

1: 9,6	↗
2: 8,4	↑
3: 8,6	↑
4: 8,5	→
5: 9,7	↘
6: 9,6	←
7: 10,2	↓
8: 9,3	↘
9: 9,8	↖
10: 8,4	↘
Serie 87,0	
Totalt 0,0	

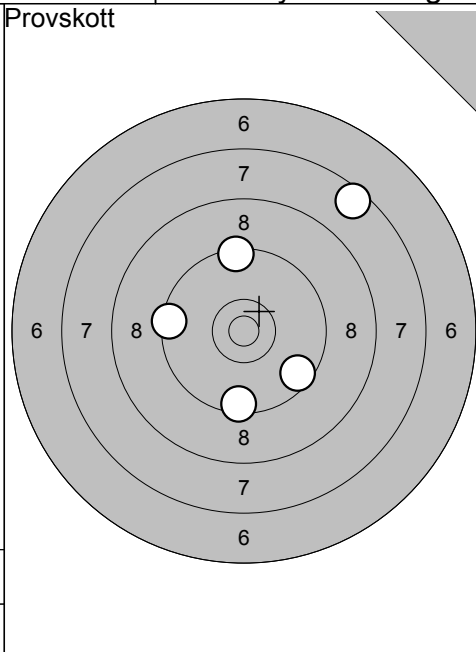

11: 9,5	↓
12: 9,4	↑
13: 7,6	↗
14: 9,6	↘
15: 9,4	←
Serie 43,0	
Totalt 0,0	

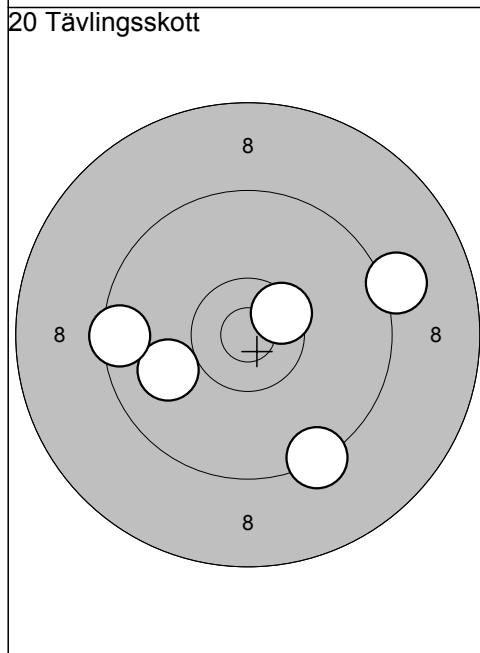

1: 9,3	↘
2: 10,0	←
3: 10,5*	↗
4: 9,5	←
5: 9,1	→
Serie 47,0	
Totalt 47,0	

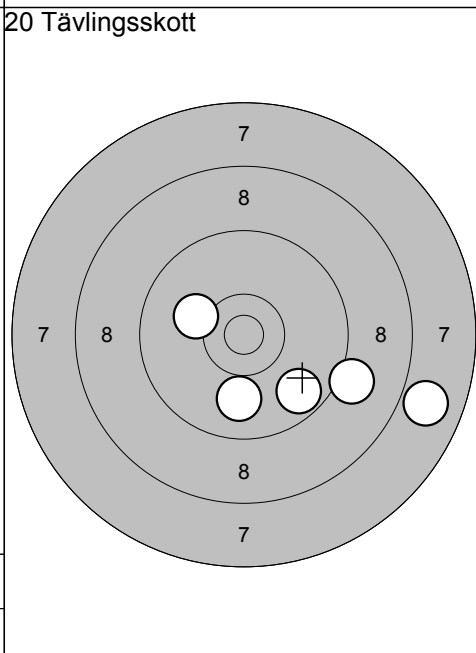

6: 7,9	→
7: 10,1	←
8: 9,1	→
9: 9,7	↘
10: 9,9	↓
Serie 44,0	
Totalt 91,0	

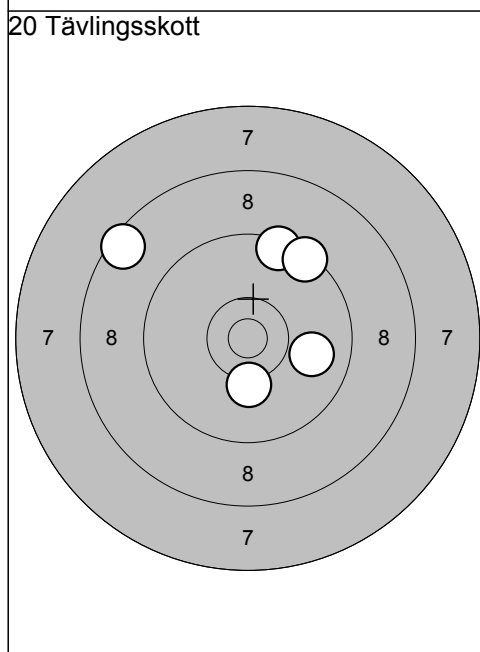

11: 9,9	→
12: 9,5	↑
13: 9,4	↗
14: 8,5	↖
15: 10,2	↓
Serie 45,0	
Totalt 136,0	

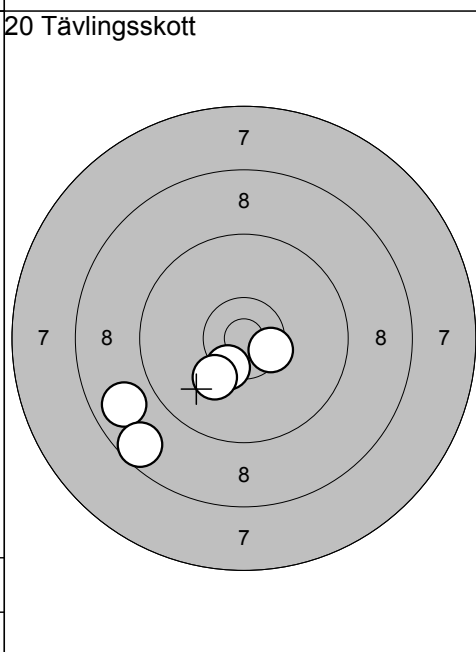

16: 8,8	↖
17: 10,5*	→
18: 10,4*	↘
19: 8,6	↖
20: 10,2	↘
Serie 46,0	
Totalt 182,0	

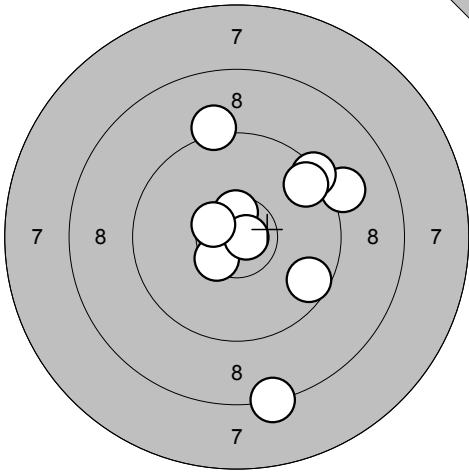
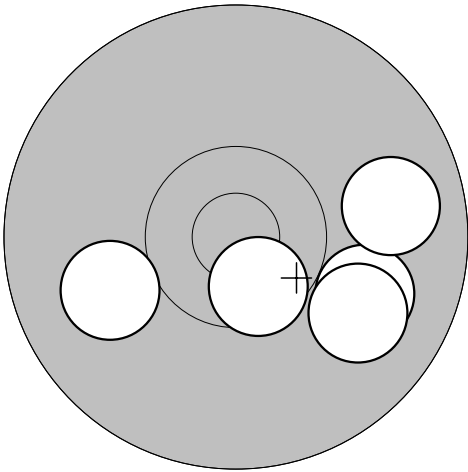
<p>Provskott</p> 	<p>20 Tävlingskott</p> 	
1: 10,6* ↑ 2: 8,3 ↓ 3: 10,5* ↙ 4: 9,1 → 5: 9,4 ↗ 6: 10,8* → 7: 9,6 ↗ 8: 9,2 ↑ 9: 10,5* ↖ 10: 9,6 ↘	1: 9,9 → 2: 10,0 ← 3: 9,9 ↘ 4: 9,8 → 5: 10,6* ↓	
Serie 93,0	Serie 47,0	
Totalt 0,0	Totalt 47,0	

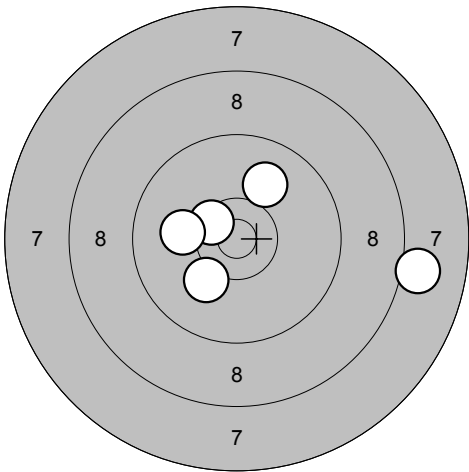
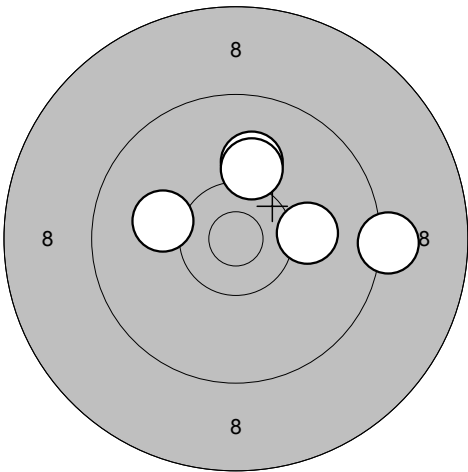
<p>20 Tävlingskott</p> 	<p>20 Tävlingskott</p> 	
6: 8,1 → 7: 10,1 ↙ 8: 10,0 ↗ 9: 10,5* ↖ 10: 10,1 ←	11: 10,1 ↑ 12: 9,2 → 13: 10,1 ← 14: 10,1 ↑ 15: 10,1 →	
Serie 48,0	Serie 49,0	
Totalt 95,0	Totalt 144,0	

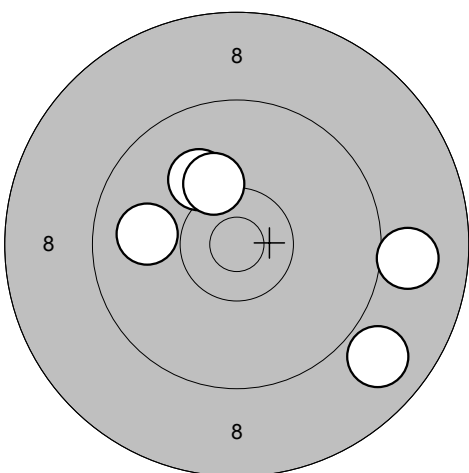
<p>20 Tävlingskott</p> 		
16: 10,1 ↖ 17: 9,9 ← 18: 10,2 ↗ 19: 8,9 ↘ 20: 9,0 →		
Serie 46,0		
Totalt 190,0		

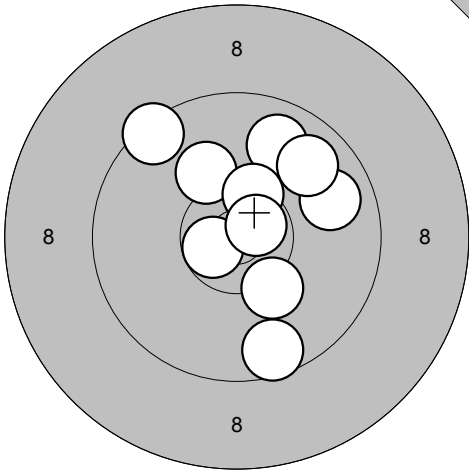
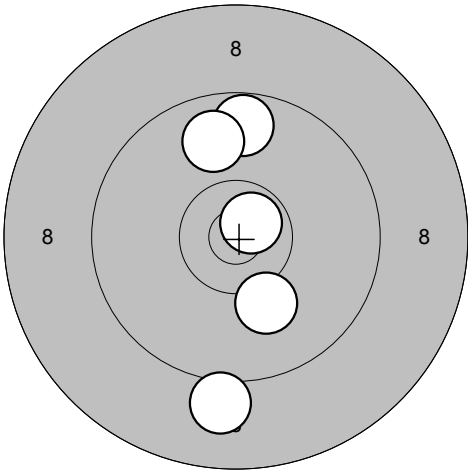
<b>Provskott</b> 	<table style="width: 100%; border-collapse: collapse;"> <tr><td>1: 9,6</td><td style="text-align: right;">↘</td></tr> <tr><td>2: 10,7*</td><td style="text-align: right;">↙</td></tr> <tr><td>3: 9,8</td><td style="text-align: right;">↗</td></tr> <tr><td>4: 9,8</td><td style="text-align: right;">→</td></tr> <tr><td>5: 10,1</td><td style="text-align: right;">↗</td></tr> <tr><td>6: 9,4</td><td style="text-align: right;">↗</td></tr> <tr><td>7: 9,8</td><td style="text-align: right;">↗</td></tr> <tr><td>8: 10,2</td><td style="text-align: right;">↘</td></tr> <tr><td>9: 10,4*</td><td style="text-align: right;">↗</td></tr> <tr><td>10: 10,7*</td><td style="text-align: right;">↗</td></tr> <tr><td colspan="2" style="border-top: 1px solid black;">Serie 95,0</td></tr> <tr><td colspan="2" style="border-top: 1px solid black;">Totalt 0,0</td></tr> </table>	1: 9,6	↘	2: 10,7*	↙	3: 9,8	↗	4: 9,8	→	5: 10,1	↗	6: 9,4	↗	7: 9,8	↗	8: 10,2	↘	9: 10,4*	↗	10: 10,7*	↗	Serie 95,0		Totalt 0,0		<b>20 Tävlingskott</b>  <table style="width: 100%; border-collapse: collapse;"> <tr><td>1: 10,7*</td><td style="text-align: right;">↗</td></tr> <tr><td>2: 9,7</td><td style="text-align: right;">↑</td></tr> <tr><td>3: 10,1</td><td style="text-align: right;">↘</td></tr> <tr><td>4: 9,0</td><td style="text-align: right;">↘</td></tr> <tr><td>5: 9,8</td><td style="text-align: right;">↑</td></tr> <tr><td colspan="2" style="border-top: 1px solid black;">Serie 47,0</td></tr> <tr><td colspan="2" style="border-top: 1px solid black;">Totalt 47,0</td></tr> </table>	1: 10,7*	↗	2: 9,7	↑	3: 10,1	↘	4: 9,0	↘	5: 9,8	↑	Serie 47,0		Totalt 47,0	
1: 9,6	↘																																							
2: 10,7*	↙																																							
3: 9,8	↗																																							
4: 9,8	→																																							
5: 10,1	↗																																							
6: 9,4	↗																																							
7: 9,8	↗																																							
8: 10,2	↘																																							
9: 10,4*	↗																																							
10: 10,7*	↗																																							
Serie 95,0																																								
Totalt 0,0																																								
1: 10,7*	↗																																							
2: 9,7	↑																																							
3: 10,1	↘																																							
4: 9,0	↘																																							
5: 9,8	↑																																							
Serie 47,0																																								
Totalt 47,0																																								

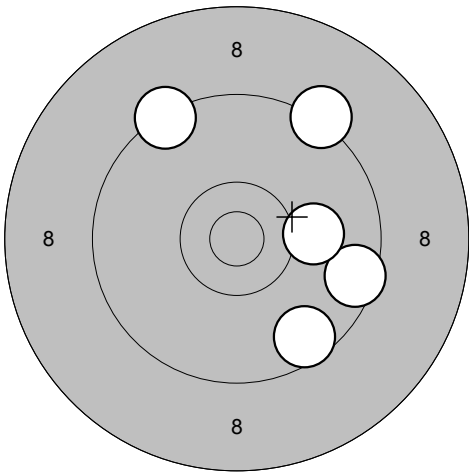
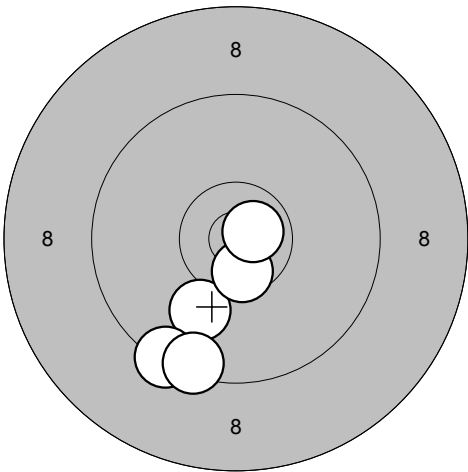
<b>20 Tävlingskott</b> 	<table style="width: 100%; border-collapse: collapse;"> <tr><td>6: 9,4</td><td style="text-align: right;">↗</td></tr> <tr><td>7: 9,6</td><td style="text-align: right;">↘</td></tr> <tr><td>8: 9,3</td><td style="text-align: right;">↗</td></tr> <tr><td>9: 9,5</td><td style="text-align: right;">→</td></tr> <tr><td>10: 10,1</td><td style="text-align: right;">→</td></tr> <tr><td colspan="2" style="border-top: 1px solid black;">Serie 46,0</td></tr> <tr><td colspan="2" style="border-top: 1px solid black;">Totalt 93,0</td></tr> </table>	6: 9,4	↗	7: 9,6	↘	8: 9,3	↗	9: 9,5	→	10: 10,1	→	Serie 46,0		Totalt 93,0		<b>20 Tävlingskott</b>  <table style="width: 100%; border-collapse: collapse;"> <tr><td>11: 10,0</td><td style="text-align: right;">↘</td></tr> <tr><td>12: 10,6*</td><td style="text-align: right;">↘</td></tr> <tr><td>13: 9,4</td><td style="text-align: right;">↘</td></tr> <tr><td>14: 10,7*</td><td style="text-align: right;">↗</td></tr> <tr><td>15: 9,4</td><td style="text-align: right;">↘</td></tr> <tr><td colspan="2" style="border-top: 1px solid black;">Serie 48,0</td></tr> <tr><td colspan="2" style="border-top: 1px solid black;">Totalt 141,0</td></tr> </table>	11: 10,0	↘	12: 10,6*	↘	13: 9,4	↘	14: 10,7*	↗	15: 9,4	↘	Serie 48,0		Totalt 141,0	
6: 9,4	↗																													
7: 9,6	↘																													
8: 9,3	↗																													
9: 9,5	→																													
10: 10,1	→																													
Serie 46,0																														
Totalt 93,0																														
11: 10,0	↘																													
12: 10,6*	↘																													
13: 9,4	↘																													
14: 10,7*	↗																													
15: 9,4	↘																													
Serie 48,0																														
Totalt 141,0																														

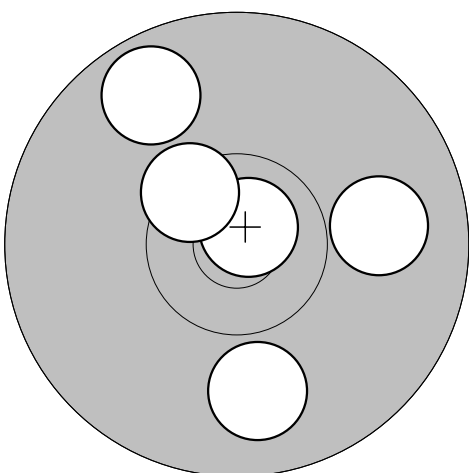
<b>20 Tävlingskott</b> 	<table style="width: 100%; border-collapse: collapse;"> <tr><td>16: 9,9</td><td style="text-align: right;">→</td></tr> <tr><td>17: 9,7</td><td style="text-align: right;">↗</td></tr> <tr><td>18: 10,8*</td><td style="text-align: right;">↗</td></tr> <tr><td>19: 9,9</td><td style="text-align: right;">↘</td></tr> <tr><td>20: 10,5*</td><td style="text-align: right;">↗</td></tr> <tr><td colspan="2" style="border-top: 1px solid black;">Serie 47,0</td></tr> <tr><td colspan="2" style="border-top: 1px solid black;">Totalt 188,0</td></tr> </table>	16: 9,9	→	17: 9,7	↗	18: 10,8*	↗	19: 9,9	↘	20: 10,5*	↗	Serie 47,0		Totalt 188,0		
16: 9,9	→															
17: 9,7	↗															
18: 10,8*	↗															
19: 9,9	↘															
20: 10,5*	↗															
Serie 47,0																
Totalt 188,0																

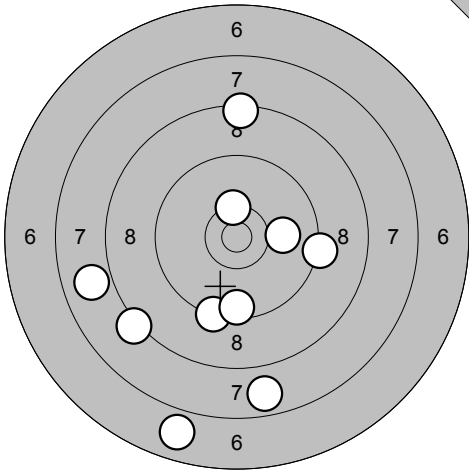
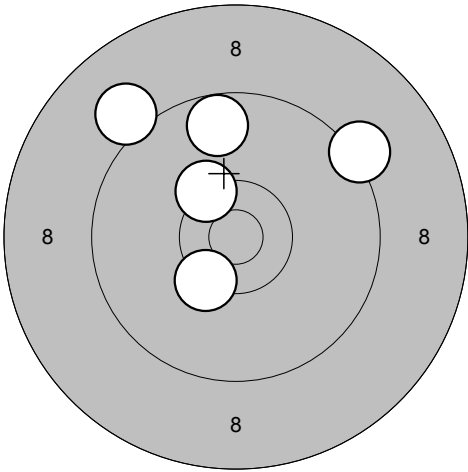
<p>Provsnitt</p> 	<p>1: 7,8 ↓</p> <p>2: 6,9 ↓</p> <p>3: 7,9 ←</p> <p>4: 9,3 ↓</p> <p>5: 9,5 ↓</p> <p>6: 8,4 ↑</p> <p>7: 10,4* ↑</p> <p>8: 10,0 →</p> <p>9: 9,3 →</p> <p>10: 8,2 ↙</p>	<p>20 Tävlingskott</p> 
Serie 83,0	Serie 47,0	
Totalt 0,0	Totalt 47,0	

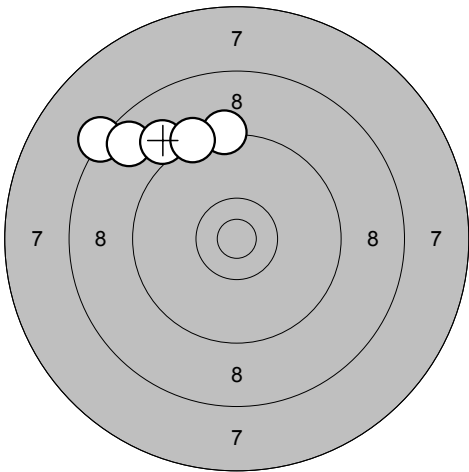
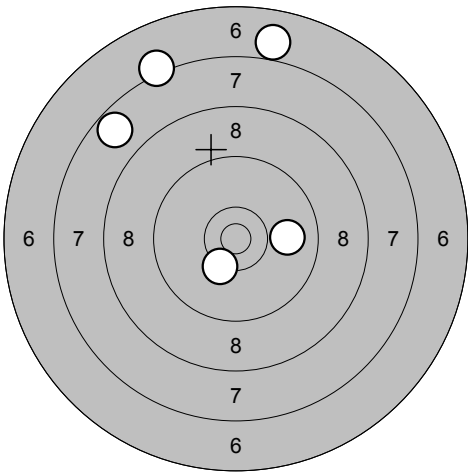
<p>20 Tävlingskott</p> 	<p>6: 8,3 ↖</p> <p>7: 9,3 ↑</p> <p>8: 8,7 ↗</p> <p>9: 9,0 ↗</p> <p>10: 9,3 ↑</p>	<p>20 Tävlingskott</p> 
Serie 43,0	Serie 40,0	
Totalt 90,0	Totalt 130,0	

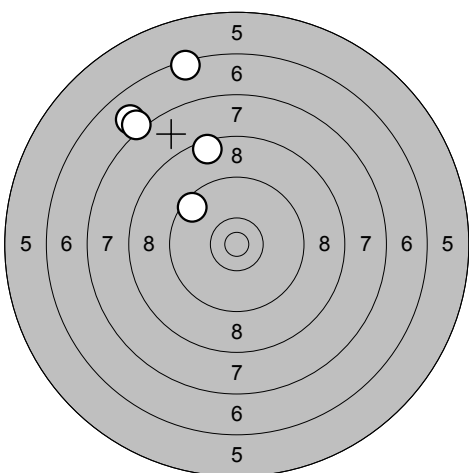
<p>20 Tävlingskott</p> 	<p>16: 6,4 ↑</p> <p>17: 9,6 ↖</p> <p>18: 7,0 ↖</p> <p>19: 8,5 ↑</p> <p>20: 7,2 ↖</p>	
Serie 37,0		
Totalt 167,0		



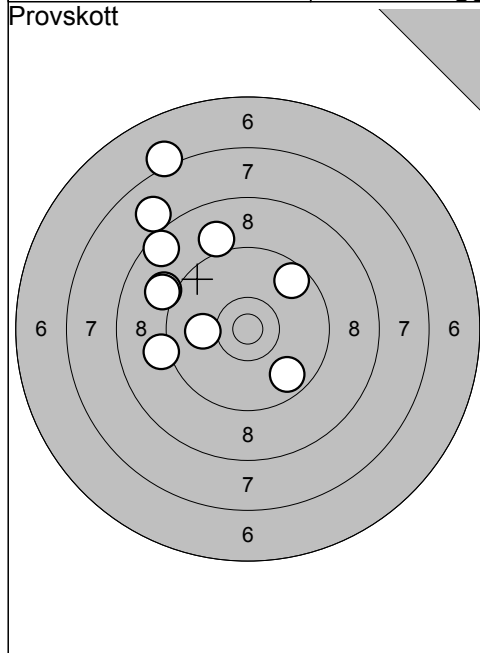

1: 9,2	←
2: 9,6	↗
3: 9,1	↖
4: 7,2	↗
5: 8,0	↗
6: 9,1	↗
7: 9,1	↖
8: 8,6	↗
9: 9,7	↘
10: 10,1	←
<b>Serie 87,0</b>	
<b>Totalt 0,0</b>	

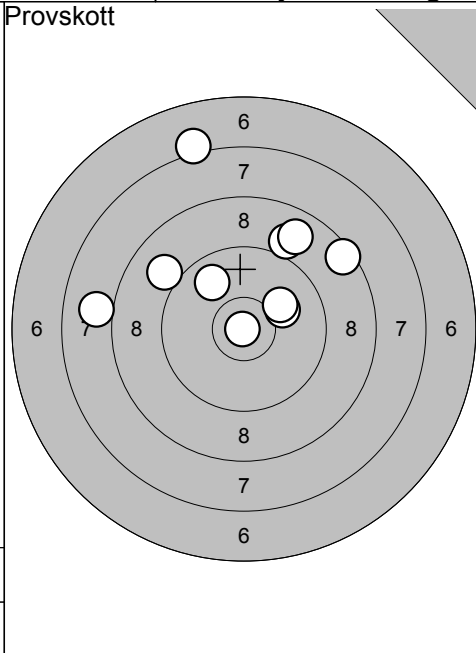

11: 10,1	↗
12: 9,0	↖
13: 9,8	↗
14: 8,0	←
15: 10,9*	←
16: 8,5	↗
17: 7,2	↑
18: 10,1	↗
19: 9,0	↗
20: 8,8	↗
<b>Serie 88,0</b>	
<b>Totalt 0,0</b>	

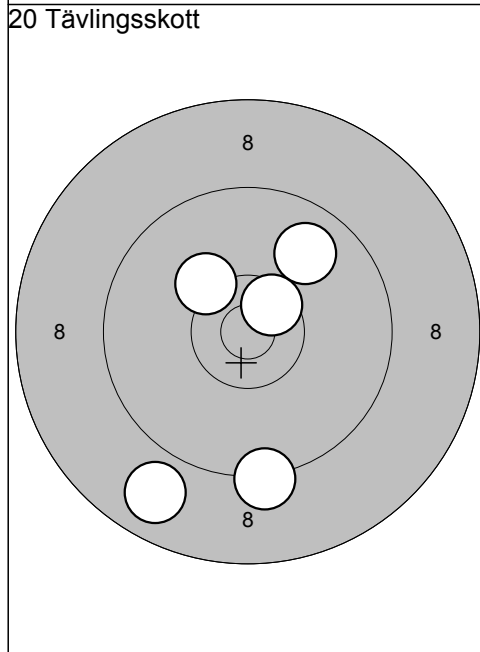

1: 9,8	↗
2: 9,3	↓
3: 8,8	↓
4: 10,2	↗
5: 10,5*	↗
<b>Serie 46,0</b>	
<b>Totalt 46,0</b>	

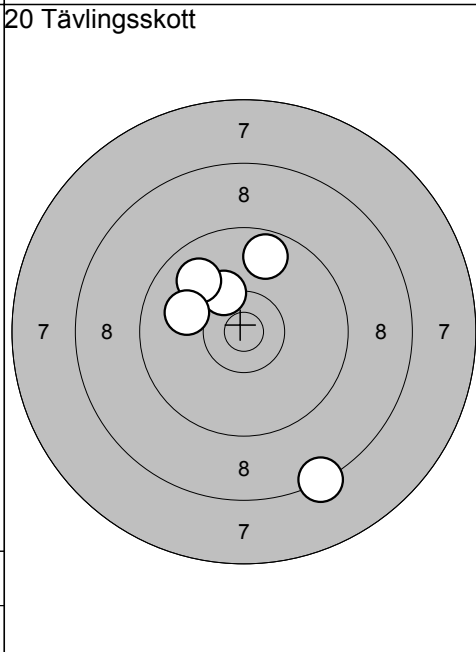

6: 9,7	↑
7: 10,3	↗
8: 9,9	↗
9: 8,3	↓
10: 10,0	←
<b>Serie 46,0</b>	
<b>Totalt 92,0</b>	

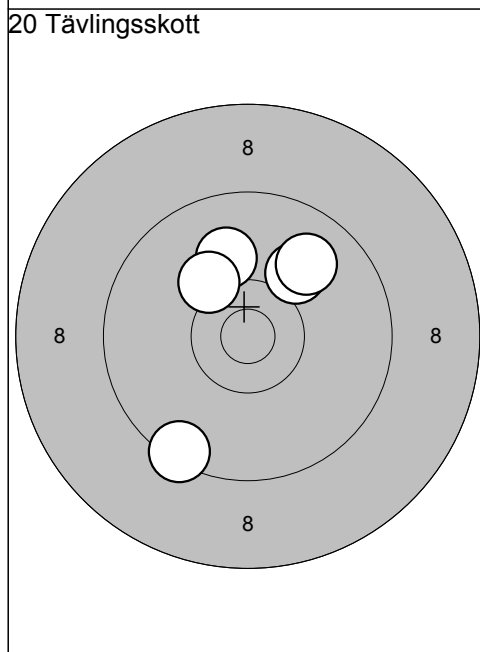

11: 10,0	↑
12: 10,2	↖
13: 10,0	↗
14: 9,4	↓
15: 9,9	↗
<b>Serie 48,0</b>	
<b>Totalt 140,0</b>	

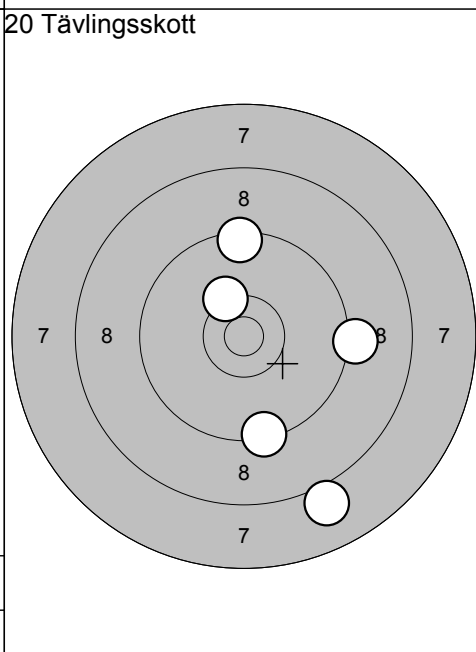

16: 8,0	↓
17: 9,4	↓
18: 9,4	↑
19: 9,2	→
20: 10,3*	↗
<b>Serie 45,0</b>	
<b>Totalt 185,0</b>	

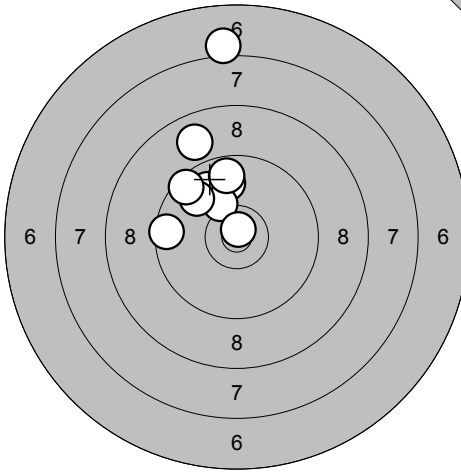
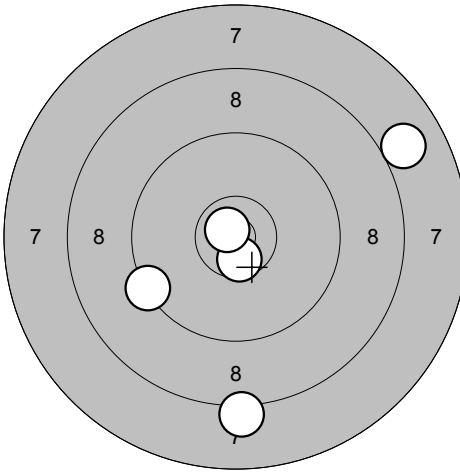
<p>Provskott</p> 	<p>20 Tävlingskott</p> 	<p>1: 9,9 ↗</p> <p>2: 9,8 ↗</p> <p>3: 7,1 ↗</p> <p>4: 8,9 ↗</p> <p>5: 10,2 ↗</p> <p>6: 9,8 ↗</p> <p>7: 9,7 ↗</p> <p>8: 9,5 ↗</p> <p>9: 9,5 ←</p> <p>10: 10,8* ↗</p>
Serie 89,0	Serie 45,0	
Totalt 0,0	Totalt 45,0	

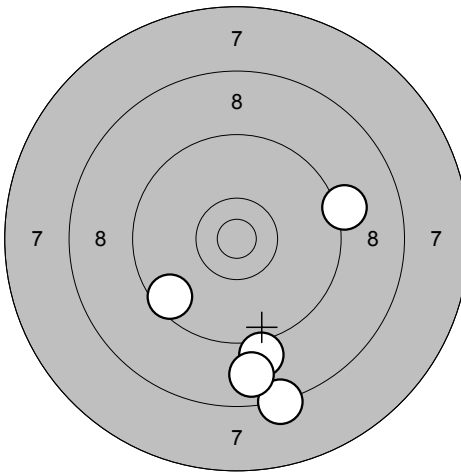
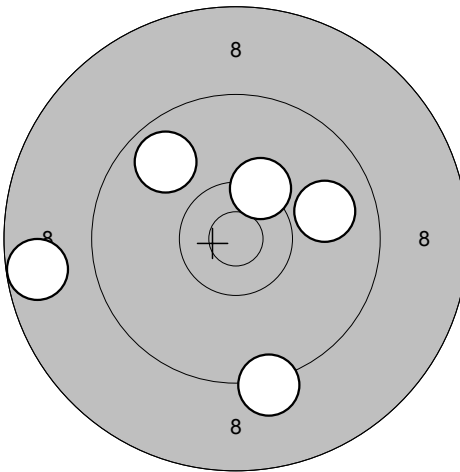
<p>20 Tävlingskott</p> 	<p>20 Tävlingskott</p> 	<p>11: 10,3* ↗</p> <p>12: 9,2 ↓</p> <p>13: 9,9 →</p> <p>14: 9,8 ↗</p> <p>15: 8,7 ←</p>
Serie 43,0	Serie 45,0	
Totalt 88,0	Totalt 133,0	

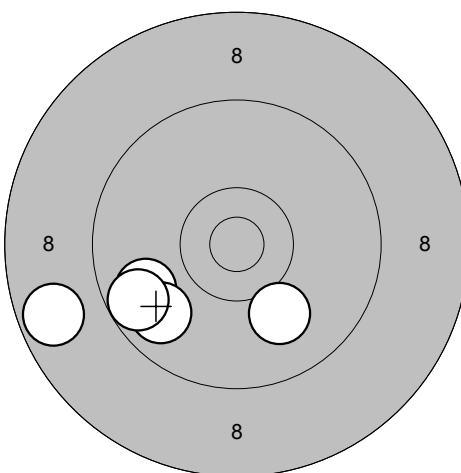
<p>20 Tävlingskott</p> 	<p>16: 9,8 ←</p> <p>17: 9,8 ←</p> <p>18: 8,7 ←</p> <p>19: 9,7 ←</p> <p>20: 10,0 ↓</p>	
Serie 45,0		
Totalt 178,0		