

Skjutlag

2

Tavla

1

Donald Johansson

50 m

Ale Skf

Ligg_ö

21.12.2014

Pskf FM ligg

Piteå Skytteförening

Provs skott

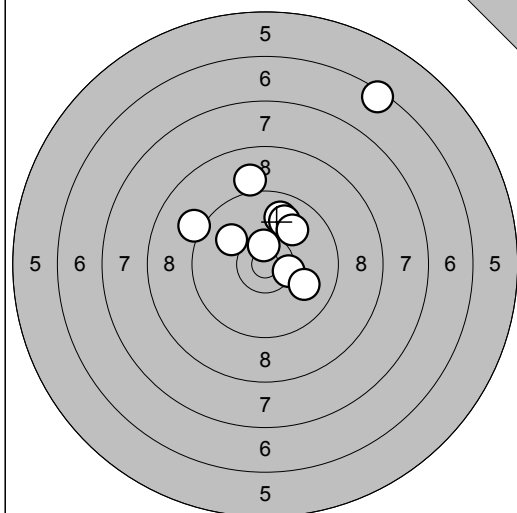

1: 6,4 ↗
 2: 10,0 ↖
 3: 9,0 ↑
 4: 9,9 ↗
 5: 9,2 ↖
 6: 10,5* ↑
 7: 9,9 ↗
 8: 10,4* →
 9: 10,0 ↘
 10: 10,0 ↗

Serie 92,0

Totalt 0,0

20 Tävlings skott

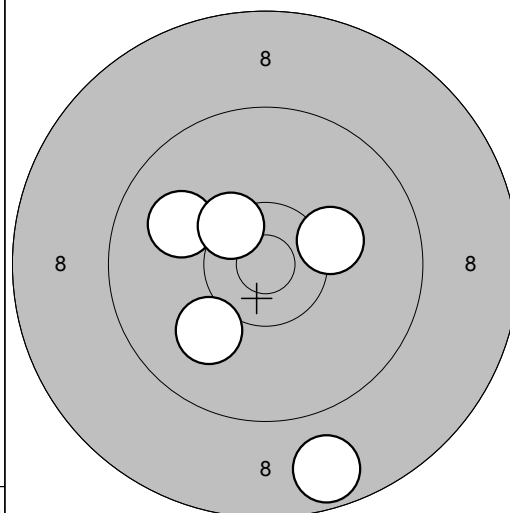

1: 10,2 →
 2: 8,7 ↓
 3: 10,0 ↖
 4: 10,4* ↗
 5: 10,0 ↘

Serie 48,0

Totalt 48,0

20 Tävlings skott

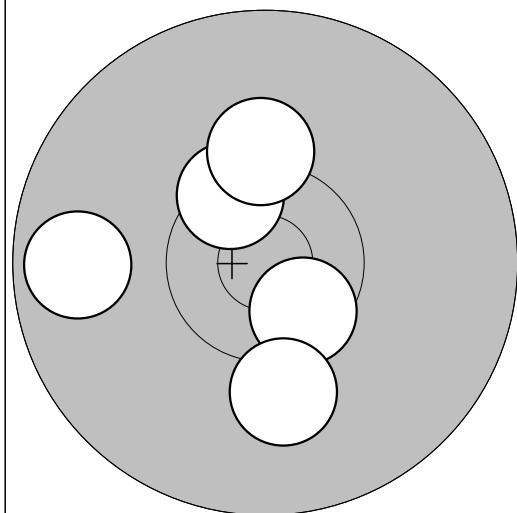

6: 10,5* ↘
 7: 10,1 ↓
 8: 9,7 ←
 9: 10,5* ↗
 10: 10,2 ↑

Serie 49,0

Totalt 97,0

20 Tävlings skott

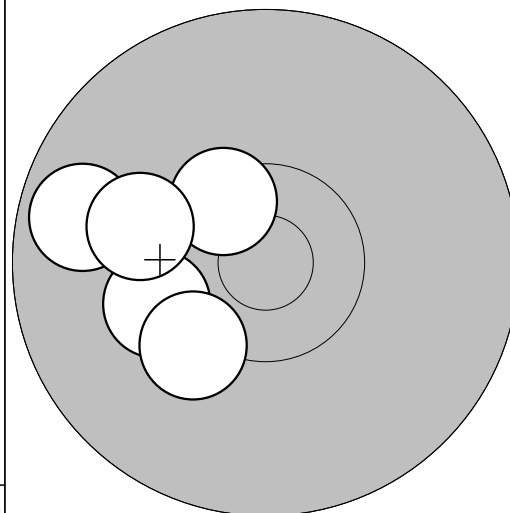

11: 10,2 ←
 12: 10,5* ↗
 13: 10,2 ↘
 14: 9,7 ←
 15: 10,1 ←

Serie 49,0

Totalt 146,0

20 Tävlings skott

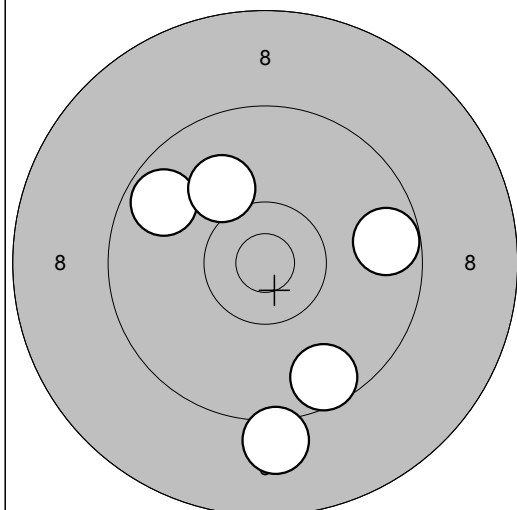

16: 9,7 ↖
 17: 9,6 ↓
 18: 9,7 →
 19: 9,1 ↓
 20: 10,1 ↗

Serie 46,0

Totalt 192,0

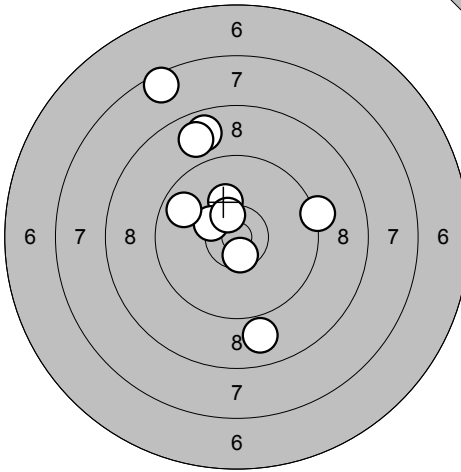
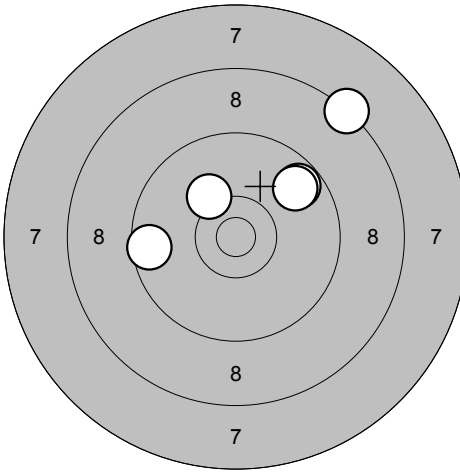
<p>Provsnitt</p> 	<p>20 Tävlingskott</p> 	<p>1: 7,6 ↗ 2: 8,8 ↗ 3: 8,8 ↗ 4: 10,2 ↗ 5: 10,4* ↗ 6: 9,8 ↗ 7: 8,9 ↓ 8: 10,5* ↗ 9: 10,6* ↓ 10: 9,3 →</p> <p>Serie 89,0 Totalt 0,0</p>	<p>1: 9,6 ← 2: 9,7 ↗ 3: 10,2 ↗ 4: 8,3 ↗ 5: 9,7 ↗</p> <p>Serie 45,0 Totalt 45,0</p>
---	---	---	--

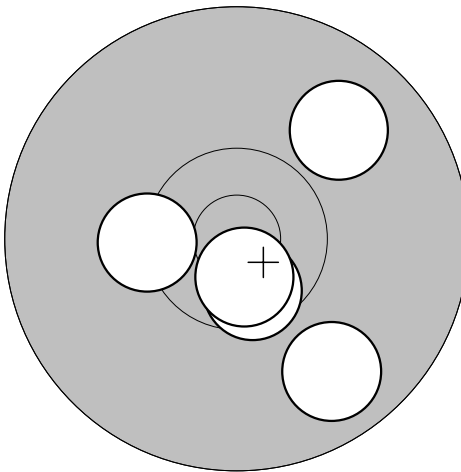
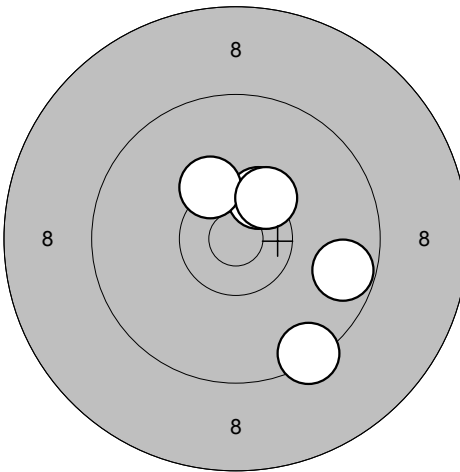
<p>20 Tävlingskott</p> 	<p>20 Tävlingskott</p> 	<p>6: 10,3* ← 7: 9,9 ↗ 8: 10,6* ↓ 9: 10,7* ↓ 10: 9,8 ↓</p> <p>Serie 48,0 Totalt 93,0</p>	<p>11: 10,4* ↗ 12: 9,7 → 13: 10,3* ↗ 14: 9,4 ↓ 15: 10,4* ↗</p> <p>Serie 48,0 Totalt 141,0</p>
--	--	--	---

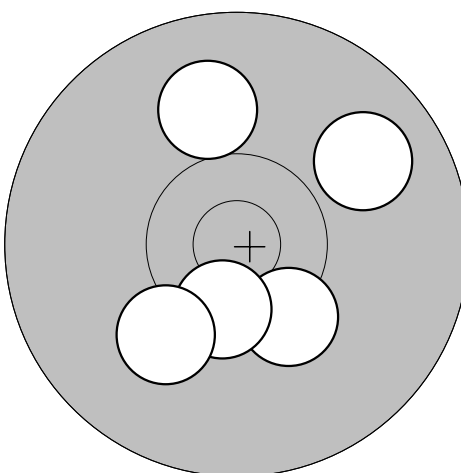
<p>20 Tävlingskott</p> 	<p>16: 9,9 ↗ 17: 10,3* ↓ 18: 10,0 ↗ 19: 10,5* ↓ 20: 10,1 ↘</p> <p>Serie 49,0 Totalt 190,0</p>		
---	---	--	--

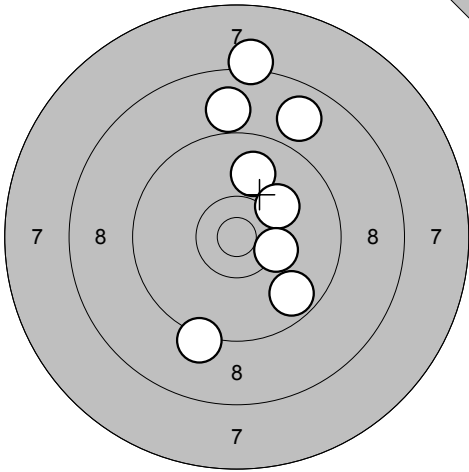
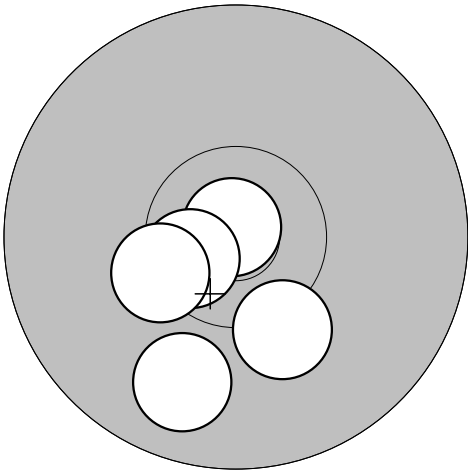
<p>Provskott</p> 	<p>1: 9,2 ↓</p> <p>2: 9,9 ↑</p> <p>3: 9,0 ↑</p> <p>4: 8,2 ↑</p> <p>5: 8,9 ↑</p> <p>6: 9,7 ↓</p> <p>7: 10,1 ↗</p> <p>8: 10,3* →</p>	<p>20 Tävlingskott</p> 
Serie 72,0	Serie 49,0	
Totalt 0,0	Totalt 49,0	

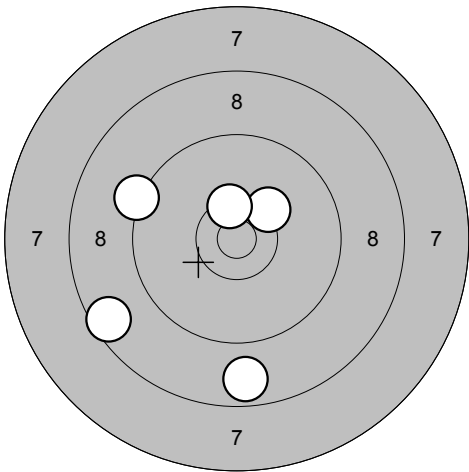
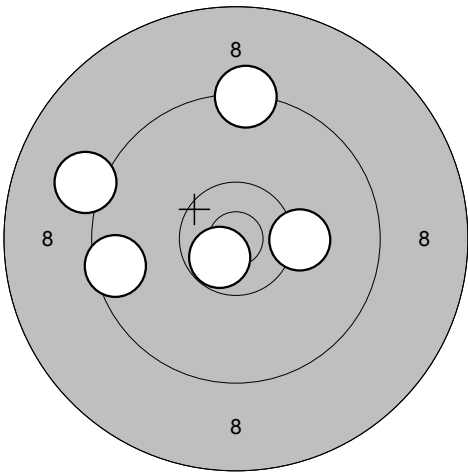
<p>20 Tävlingskott</p> 	<p>6: 8,7 ↓</p> <p>7: 8,6 ↙</p> <p>8: 10,3 ↗</p> <p>9: 9,3 ↙</p> <p>10: 10,4* ↑</p>	<p>20 Tävlingskott</p> 
Serie 45,0	Serie 47,0	
Totalt 94,0	Totalt 141,0	

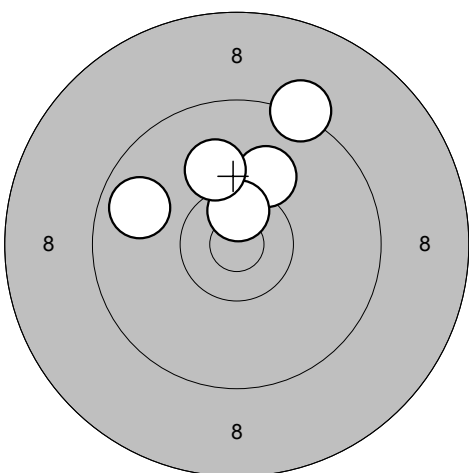
<p>20 Tävlingskott</p> 	<p>16: 9,3 ↗</p> <p>17: 10,1 ↗</p> <p>18: 10,6* ↑</p> <p>19: 9,8 ↙</p> <p>20: 10,1 ↑</p>	
Serie 48,0		
Totalt 189,0		

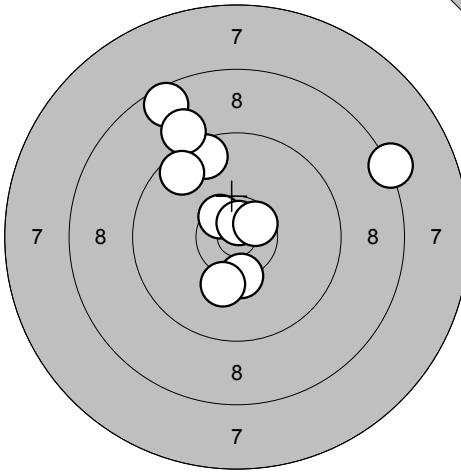
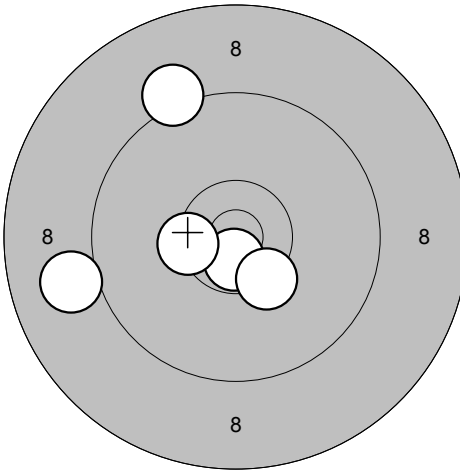
<p>Provsnitt</p> 	<p>20 Tävlingskott</p> <p>1: 8,3 →</p> <p>2: 8,6 ↗</p> <p>3: 9,6 ↗</p> <p>4: 10,5* ↗</p> <p>5: 10,3* ↓</p> <p>6: 9,1 ↗</p> <p>7: 10,2 ↓</p> <p>8: 9,6 ↗</p> <p>9: 10,7* ↑</p> <p>10: 10,6* ↗</p>	<p>20 Tävlingskott</p>  <p>1: 10,7* ↓</p> <p>2: 9,2 ↗</p> <p>3: 10,4* ↓</p> <p>4: 10,4* ←</p> <p>5: 9,0 ←</p>
Serie 93,0	Serie 48,0	Serie 48,0
Totalt 0,0	Totalt 48,0	Totalt 48,0

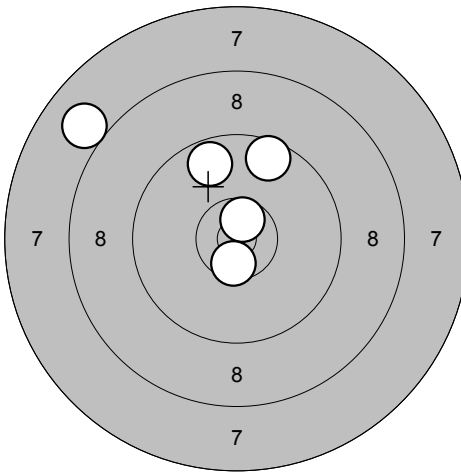
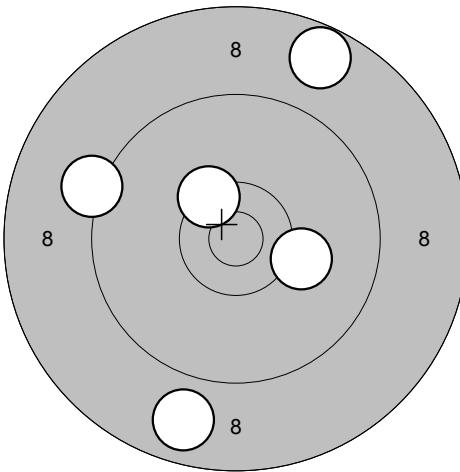
<p>20 Tävlingskott</p> 	<p>20 Tävlingskott</p> <p>6: 8,0 ↖</p> <p>7: 10,6* ↑</p> <p>8: 9,7 ↗</p> <p>9: 9,6 ↗</p> <p>10: 10,6* ↓</p>	<p>20 Tävlingskott</p>  <p>11: 10,2 →</p> <p>12: 8,8 ↓</p> <p>13: 10,4* ↗</p> <p>14: 8,7 ↗</p> <p>15: 9,2 ←</p>
Serie 46,0	Serie 45,0	Serie 45,0
Totalt 94,0	Totalt 139,0	Totalt 139,0

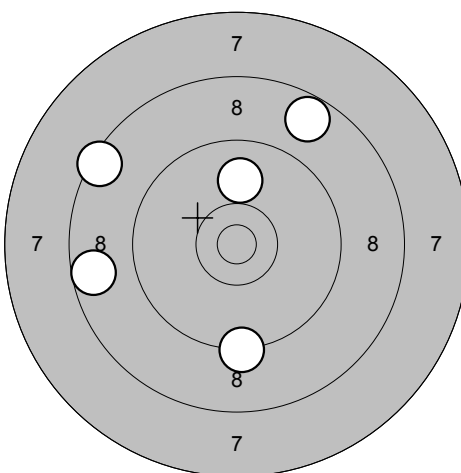
<p>20 Tävlingskott</p> 	<p>16: 9,3 ↓</p> <p>17: 8,5 ↖</p> <p>18: 8,7 ←</p> <p>19: 10,0 ↑</p> <p>20: 8,7 ↗</p>	
Serie 43,0		
Totalt 182,0		

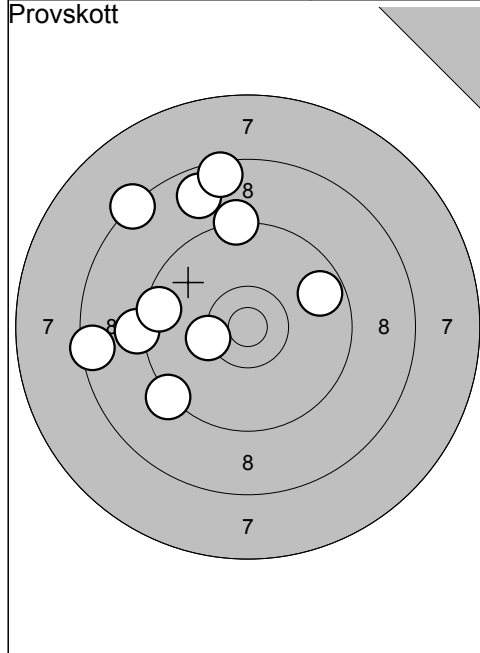

1: 9,3	↑
2: 8,5	←
3: 9,7	→
4: 10,3*	←
5: 8,8	↑
6: 9,2	←
7: 9,3	↙
8: 9,5	←
9: 8,3	↗
10: 8,5	↑
<hr/>	
Serie	87,0
Totalt	0,0

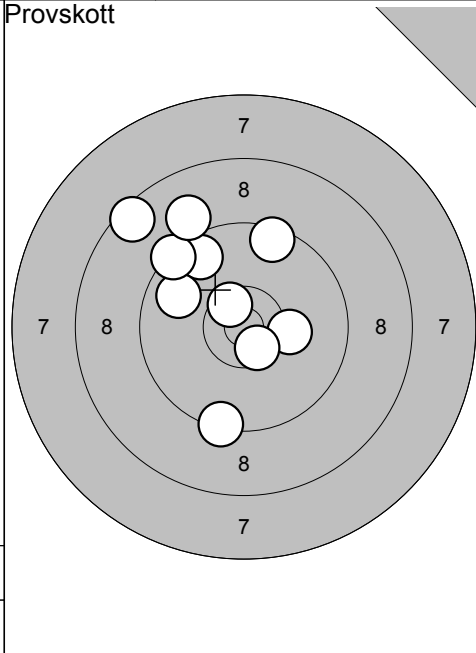

11: 9,4	↓
12: 9,7	↗
13: 9,8	↖
14: 9,5	↑
15: 10,5*	↗
16: 10,2	→
17: 9,4	↗
18: 9,0	↗
19: 10,6*	↓
20: 8,5	↗
<hr/>	
Serie	92,0
Totalt	0,0

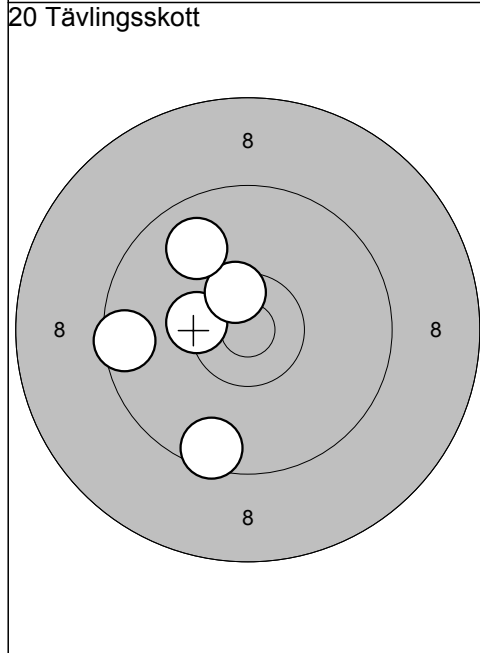

1: 10,4*	←
2: 10,5*	↑
3: 9,9	↗
4: 9,5	←
5: 9,5	↓
<hr/>	
Serie	47,0
Totalt	47,0

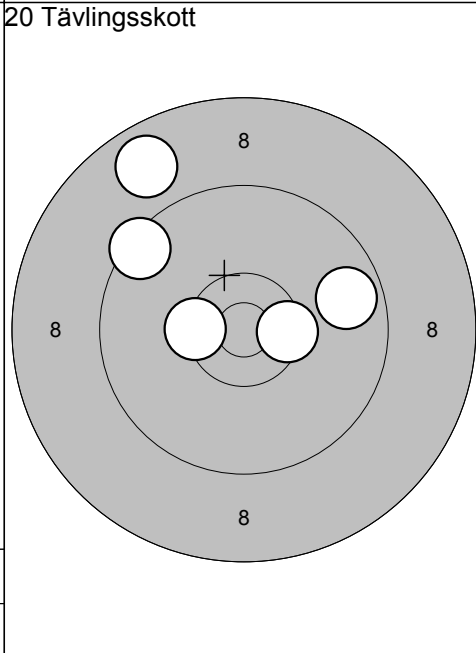

6: 9,5	↗
7: 10,4*	→
8: 9,7	→
9: 8,8	↗
10: 10,4*	←
<hr/>	
Serie	46,0
Totalt	93,0

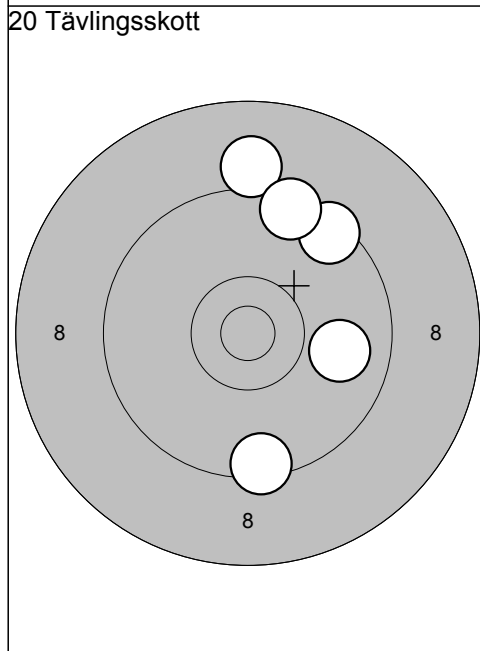

11: 9,9	→
12: 9,5	↗
13: 9,0	↑
14: 9,4	↑
15: 9,4	↓
<hr/>	
Serie	45,0
Totalt	138,0

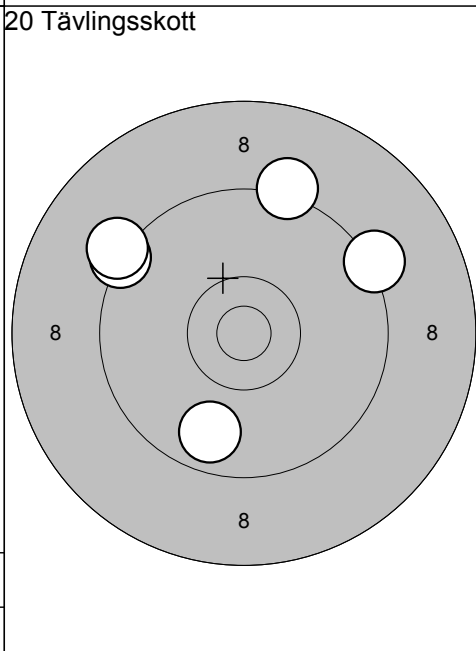

16: 9,2	↑
17: 9,3	↖
18: 9,2	↗
19: 9,2	↖
20: 9,8	↓
<hr/>	
Serie	45,0
Totalt	183,0

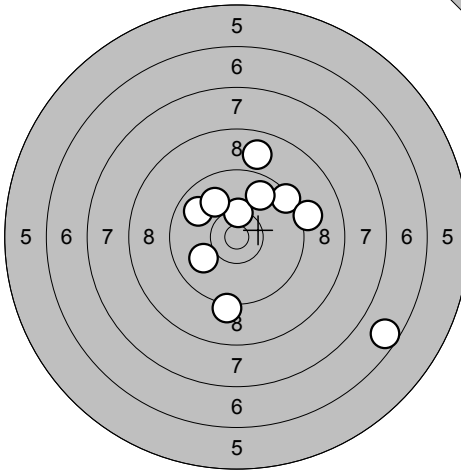
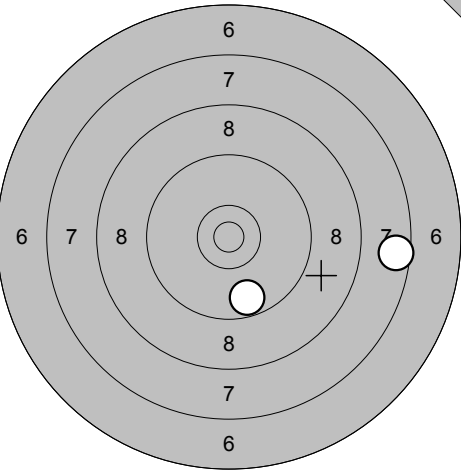
<p>Provskott</p> 	<p>1: 9,4 ↗ 2: 6,6 ➡ 3: 9,8 ↖ 4: 10,0 ↙ 5: 9,2 ↓ 6: 10,4* ↑ 7: 8,9 ↑ 8: 9,8 ↗ 9: 10,0 ↖ 10: 9,1 ➡</p> <table border="1" style="width:100%; border-collapse: collapse;"> <tr> <td style="width:50%;">Serie</td> <td style="width:50%;">89,0</td> </tr> <tr> <td>Totalt</td> <td>0,0</td> </tr> </table>	Serie	89,0	Totalt	0,0	<p>Provskott</p> 	<p>11: 9,7 ↓ 12: 7,6 ➡</p> <table border="1" style="width:100%; border-collapse: collapse;"> <tr> <td style="width:50%;">Serie</td> <td style="width:50%;">16,0</td> </tr> <tr> <td>Totalt</td> <td>0,0</td> </tr> </table>	Serie	16,0	Totalt	0,0
Serie	89,0										
Totalt	0,0										
Serie	16,0										
Totalt	0,0										

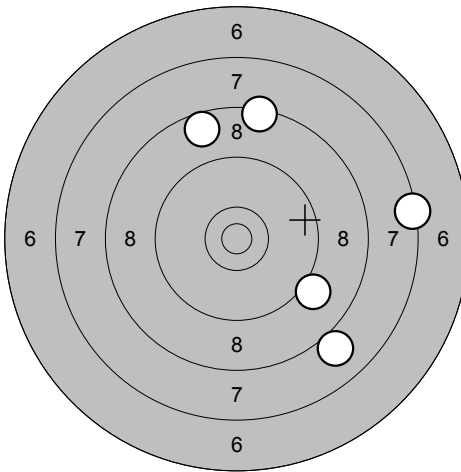
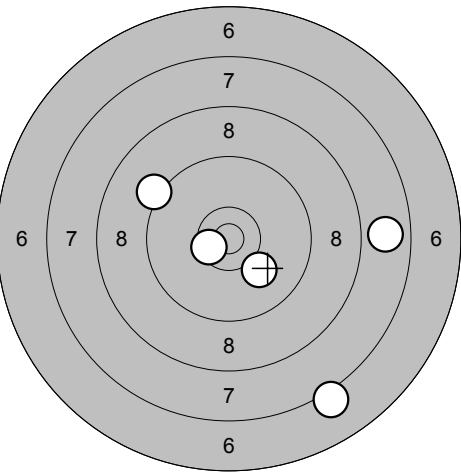
<p>20 Tävlingskott</p> 	<p>1: 8,0 ↘ 2: 8,4 ↑ 3: 9,1 ↘ 4: 8,7 ↑ 5: 7,4 ➡</p> <table border="1" style="width:100%; border-collapse: collapse;"> <tr> <td style="width:50%;">Serie</td> <td style="width:50%;">40,0</td> </tr> <tr> <td>Totalt</td> <td>40,0</td> </tr> </table>	Serie	40,0	Totalt	40,0	<p>20 Tävlingskott</p> 	<p>6: 9,2 ↖ 7: 10,1 ↘ 8: 10,5* ↙ 9: 7,1 ↓ 10: 7,8 ➡</p> <table border="1" style="width:100%; border-collapse: collapse;"> <tr> <td style="width:50%;">Serie</td> <td style="width:50%;">43,0</td> </tr> <tr> <td>Totalt</td> <td>83,0</td> </tr> </table>	Serie	43,0	Totalt	83,0
Serie	40,0										
Totalt	40,0										
Serie	43,0										
Totalt	83,0										

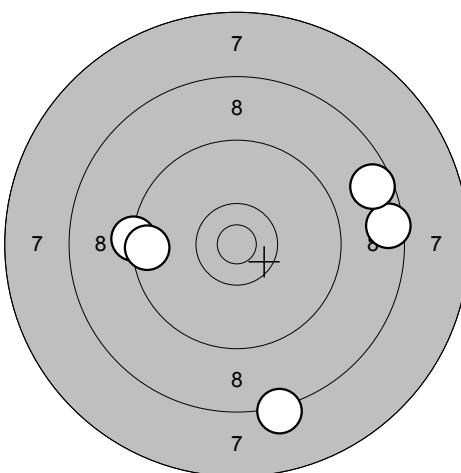
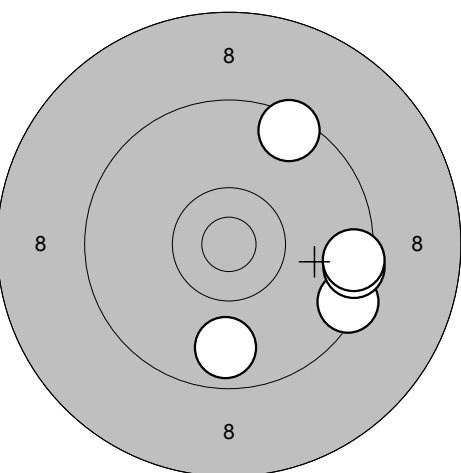
<p>20 Tävlingskott</p> 	<p>11: 8,5 ➡ 12: 8,6 ➡ 13: 8,2 ↓ 14: 9,3 ← 15: 9,5 ←</p> <table border="1" style="width:100%; border-collapse: collapse;"> <tr> <td style="width:50%;">Serie</td> <td style="width:50%;">42,0</td> </tr> <tr> <td>Totalt</td> <td>125,0</td> </tr> </table>	Serie	42,0	Totalt	125,0	<p>20 Tävlingskott</p> 	<p>16: 9,4 ➡ 17: 9,5 ➡ 18: 9,5 ➡ 19: 9,8 ↓ 20: 9,5 ↗</p> <table border="1" style="width:100%; border-collapse: collapse;"> <tr> <td style="width:50%;">Serie</td> <td style="width:50%;">45,0</td> </tr> <tr> <td>Totalt</td> <td>170,0</td> </tr> </table>	Serie	45,0	Totalt	170,0
Serie	42,0										
Totalt	125,0										
Serie	45,0										
Totalt	170,0										