

1: 9,6	↗
2: 9,0	↗
3: 10,1	↗
4: 9,8	↘
5: 10,3	↗
Serie	47,0
Totalt	0,0

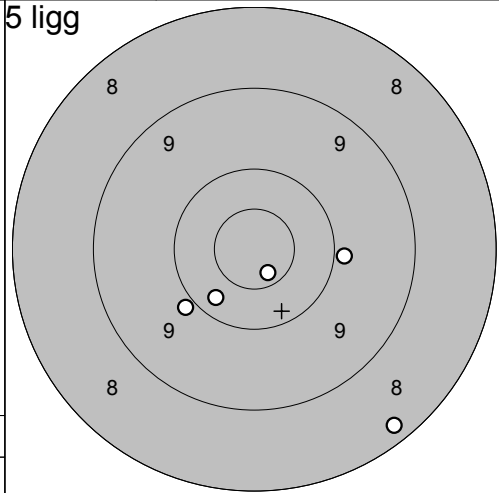

1: 10,7*	↘
2: 9,9	→
3: 10,3	↘
4: 9,9	↘
5: 8,2	↘
Serie	46,0
Totalt	46,0

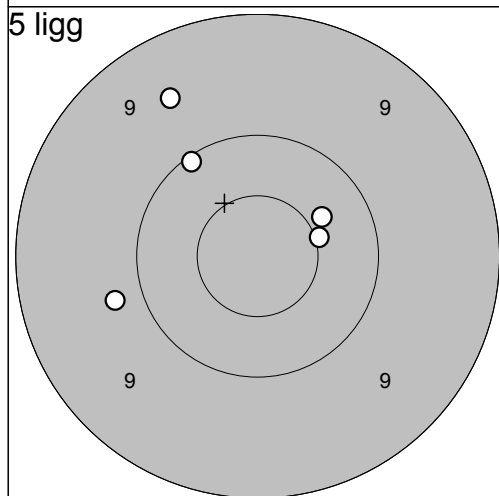

1: 10,5*	→
2: 9,8	←
3: 10,4	↗
4: 10,1	↗
5: 9,5	↗
Serie	48,0
Totalt	94,0

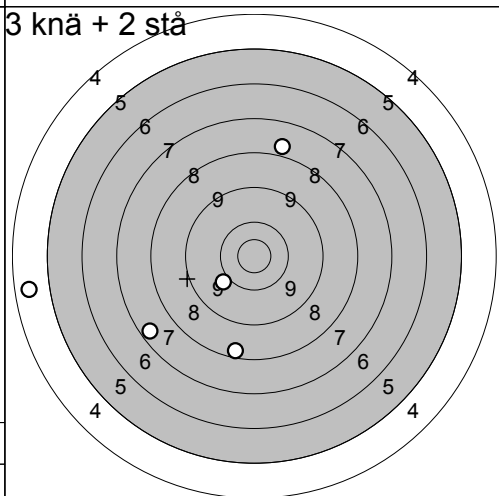

1: 8,4	↘
2: 7,9	↑
3: 10,0	↘
4: 4,6	←
5: 7,5	↘
Serie	36,0
Totalt	130,0

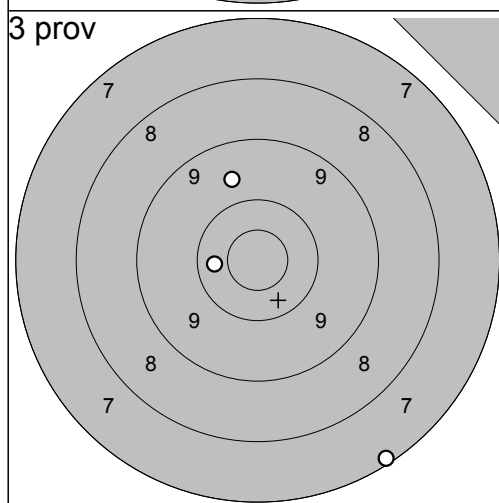

1: 7,2	↘
2: 10,4	←
3: 9,7	↗
Serie	26,0
Totalt	130,0

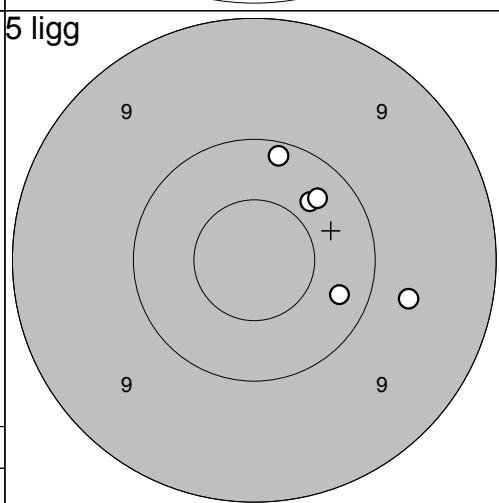

1: 10,1	↑
2: 10,3	→
3: 10,4	↗
4: 10,3	↗
5: 9,7	→
Serie	49,0
Totalt	179,0

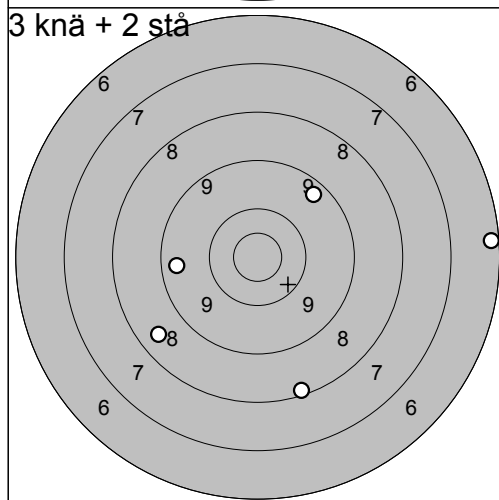

1: 9,4	←
2: 9,4	↗
3: 8,5	↘
4: 8,2	↘
5: 6,3	→
Serie	40,0
Totalt	219,0

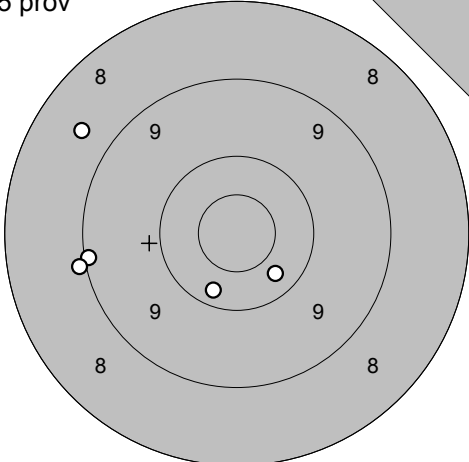
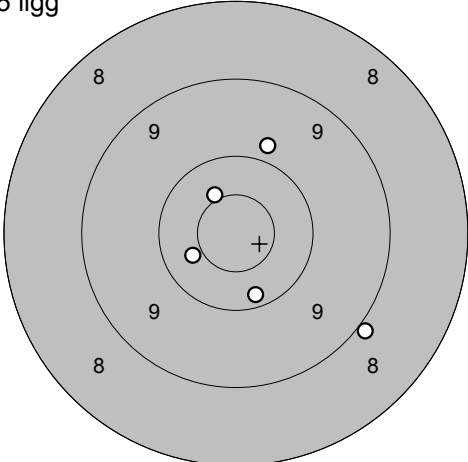
<p>5 prov</p>  <p style="text-align: right;">Serie 46,0 Totalt 0,0</p>	<p>5 ligg</p>  <p style="text-align: right;">Serie 48,0 Totalt 48,0</p>
--	---

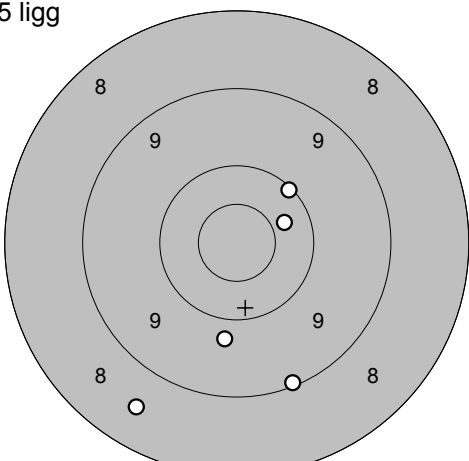
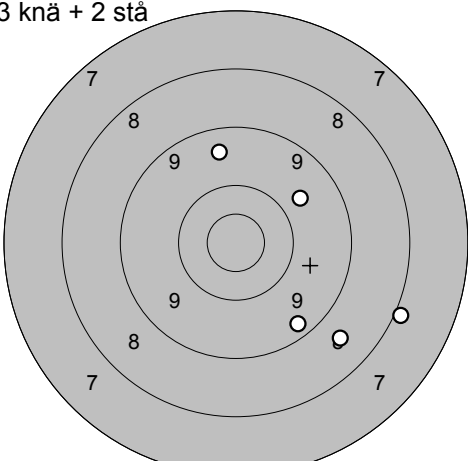
<p>5 ligg</p>  <p style="text-align: right;">Serie 46,0 Totalt 94,0</p>	<p>3 knä + 2 stå</p>  <p style="text-align: right;">Serie 43,0 Totalt 137,0</p>
--	--

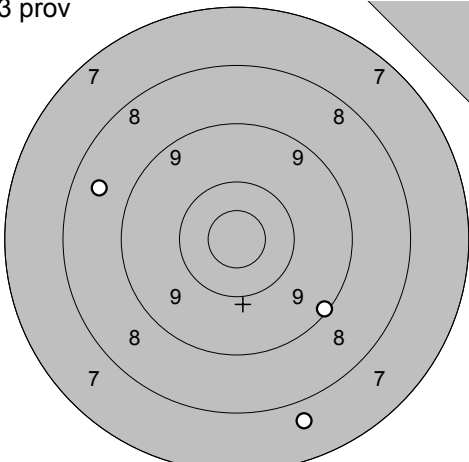
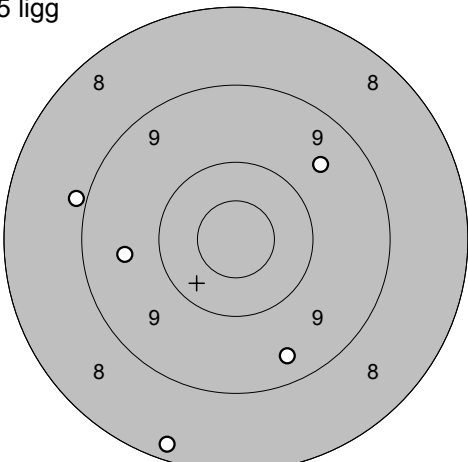
<p>3 prov</p>  <p style="text-align: right;">Serie 24,0 Totalt 137,0</p>	<p>5 ligg</p>  <p style="text-align: right;">Serie 43,0 Totalt 180,0</p>
--	--

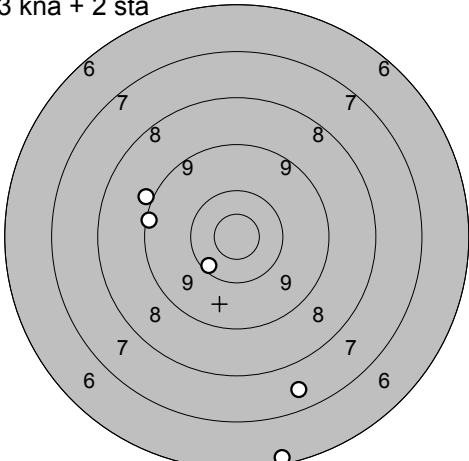
<p>3 knä + 2 stå</p>  <p style="text-align: right;">Serie 41,0 Totalt 221,0</p>	
---	--

<p>5 prov</p>	<p>5 ligg</p>
Serie 44,0 Totalt 0,0	Serie 47,0 Totalt 47,0

<p>5 ligg</p>	<p>3 knä + 2 stå</p>
Serie 48,0 Totalt 95,0	Serie 48,0 Totalt 143,0

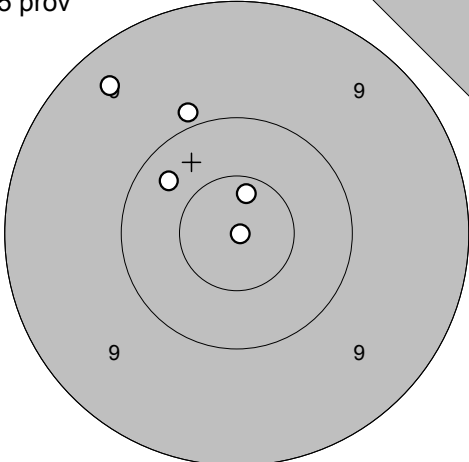
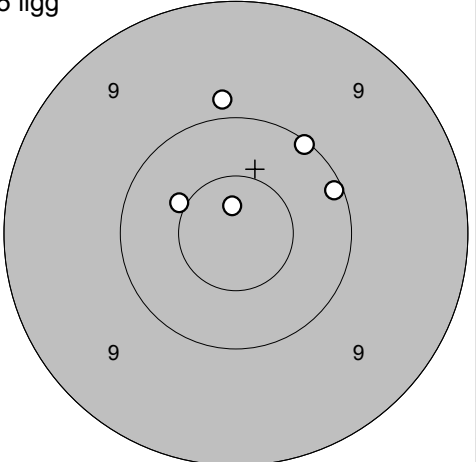

<p>3 prov</p>	<p>5 ligg</p>
Serie 29,0 Totalt 143,0	Serie 50,0 Totalt 193,0

<p>3 knä + 2 stå</p>	
Serie 48,0 Totalt 241,0	

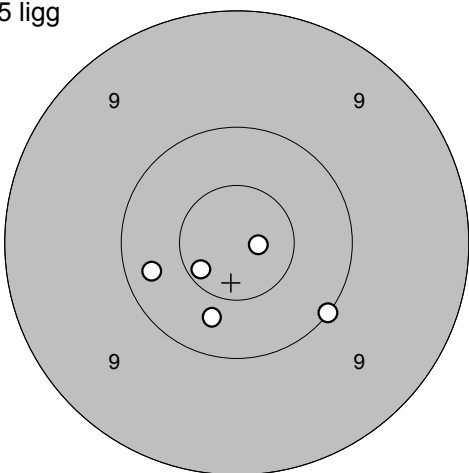
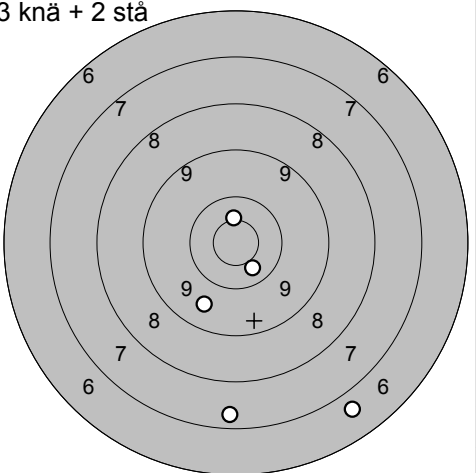
<p>5 prov</p> 	<p>5 ligg</p> 	
Serie 48,0 Totalt 0,0	Serie 49,0 Totalt 49,0	

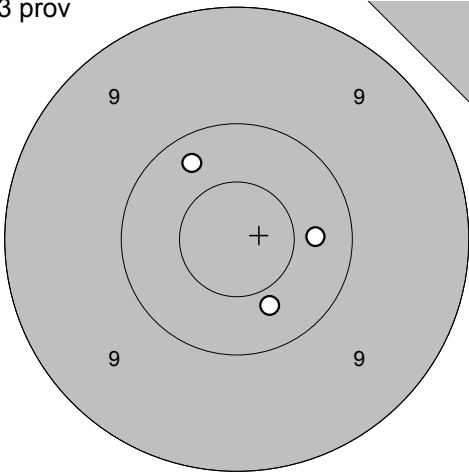
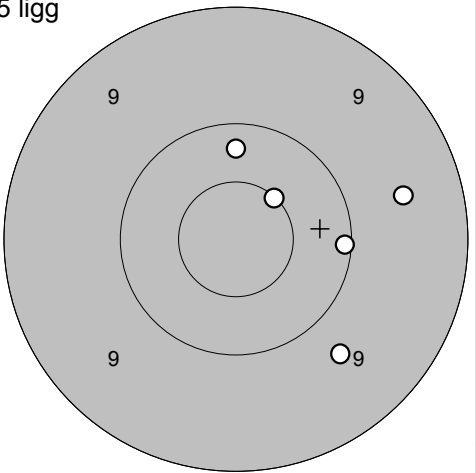
<p>5 ligg</p> 	<p>3 knä + 2 stå</p> 	
Serie 50,0 Totalt 99,0	Serie 42,0 Totalt 141,0	

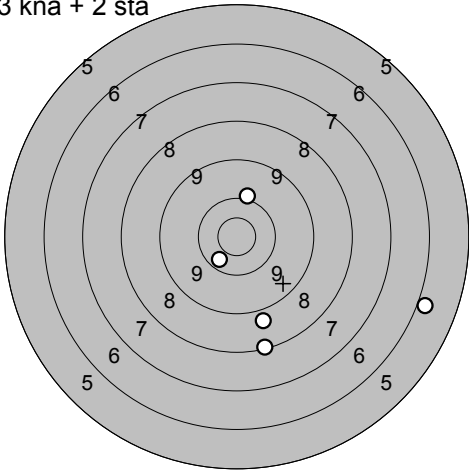
<p>3 prov</p> 	<p>5 ligg</p> 	
Serie 30,0 Totalt 141,0	Serie 48,0 Totalt 189,0	

<p>3 knä + 2 stå</p> 	<p>5 ligg</p> 	
Serie 42,0 Totalt 231,0	Serie 48,0 Totalt 189,0	

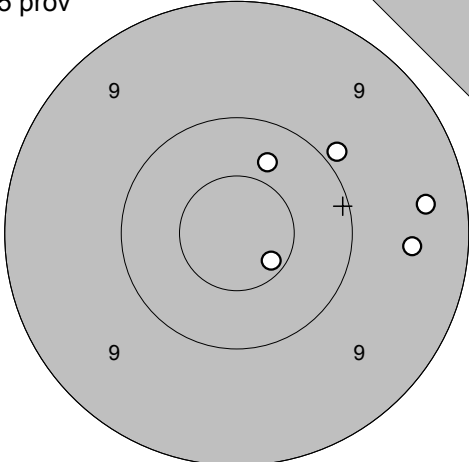
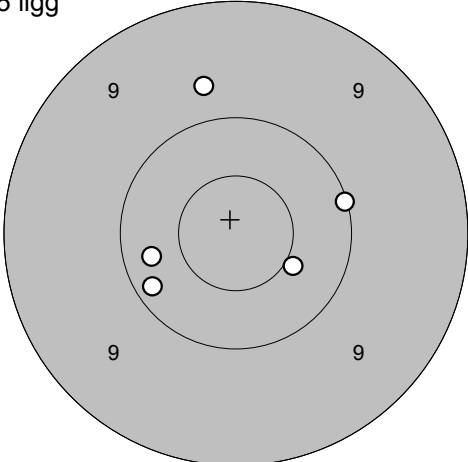
<p>5 prov</p> 	<p>1: 9,4 → 2: 9,9 ↗ 3: 10,4 ↑ 4: 9,5 → 5: 10,6* ↘</p>	<p>5 ligg</p> 	<p>1: 10,2 ↙ 2: 9,7 ↑ 3: 10,3 ↖ 4: 10,5* ↗ 5: 10,1 →</p>
Serie 47,0		Serie 49,0	
Totalt 0,0		Totalt 49,0	

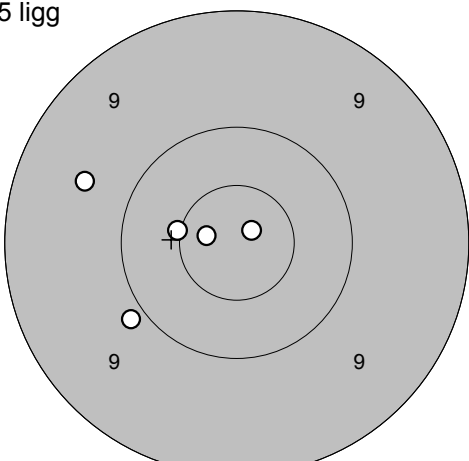
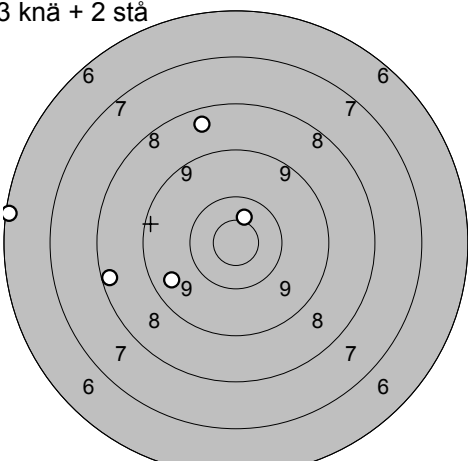
<p>5 ligg</p> 	<p>1: 10,8* ← 2: 9,9 ↙ 3: 10,5* ← 4: 9,6 ↙ 5: 10,9* ↗</p>	<p>3 knä + 2 stå</p> 	<p>1: 10,5* ↑ 2: 9,5 ↙ 3: 8,3 ← 4: 8,5 ↑ 5: 6,2 ←</p>
Serie 48,0		Serie 41,0	
Totalt 97,0		Totalt 138,0	

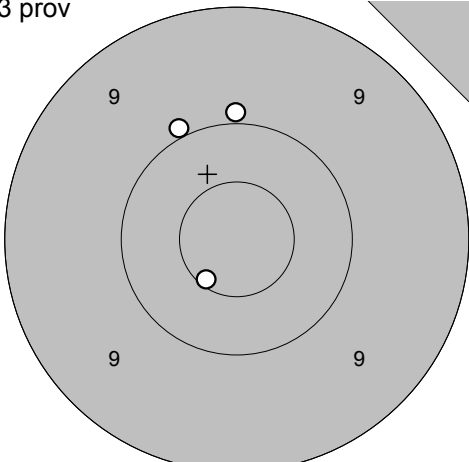
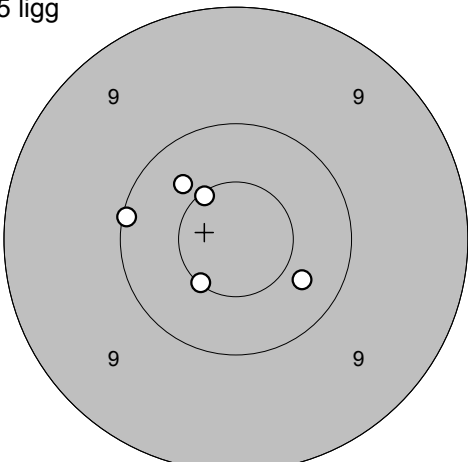
<p>3 prov</p> 	<p>1: 10,0 ↗ 2: 9,9 ↑ 3: 10,6* ↘</p>	<p>5 ligg</p> 	<p>1: 10,4 ↗ 2: 10,5* ↙ 3: 10,1 ↖ 4: 10,4 ↗ 5: 10,6* ↗</p>
Serie 29,0		Serie 50,0	
Totalt 138,0		Totalt 188,0	

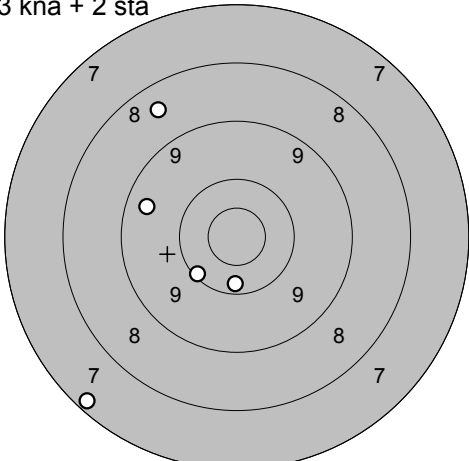
<p>3 knä + 2 stå</p> 	<p>1: 10,2 ↙ 2: 9,5 ↖ 3: 10,3 ↓ 4: 7,3 ↙ 5: 8,5 ↗</p>		
Serie 44,0			
Totalt 232,0			